

T-8421B

T-8422B

---

2本針本縫ダイレクトドライブミシン

2本針本縫ダイレクトドライブ自動糸切りミシン

TWIN NEEDLE DIRECT DRIVE LOCK STITCHER

TWIN NEEDLE DIRECT DRIVE LOCK STITCHER WITH THREAD TRIMMER

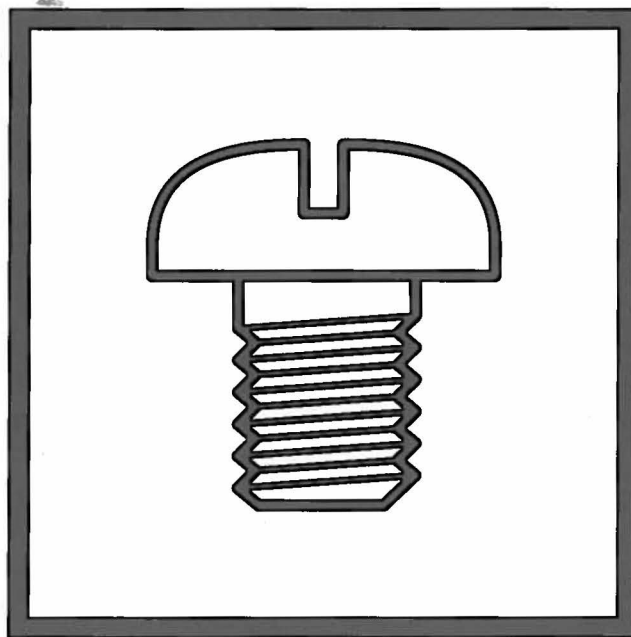

---

brother®

最新の部品情報は Parts Navigation でご覧いただけます。  
The latest parts information, refer to the Parts Navigation.

<http://partsbook.brother.co.jp/partsnavi/jpn/>  
<http://partsbook.brother.co.jp/partsnavi/eng/>

## 型式板の見方



- 3: 中厚物
- 5: 厚物
- F: ファンデーション

- 0: 微量給油仕様
- 3: セミドライ仕様



- 3: 中厚物
- 5: 厚物

- 0: 微量給油仕様
- 3: セミドライ仕様

## Description of model plate

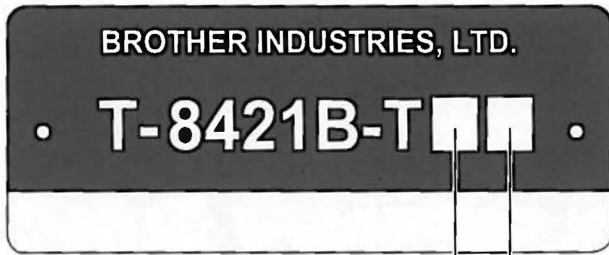

3: Medium-weight materials  
5: Heavy-weight materials  
F: Foundation garments

0: Minimum lubrication type  
3: Semi dry type



3: Medium-weight materials  
5: Heavy-weight materials

0: Minimum lubrication type  
3: Semi dry type

## パーツブックご利用に際して

1. この本は、2006年11月のデータに基づいて作成されたものです。
2. 部品は予告なしに設計変更される場合があります。
3. 組単位で補給する部品は、破線で示してあります。

### 目 次

A. 主体関係 .....	1
B. 上軸関係 .....	3
C. 針棒揺動関係 .....	5
D. 押え関係 .....	7
E. 送り関係 .....	9
F. 逆転関係 .....	11
G. 送り軸関係 .....	13
H. ゲージ関係 .....	15
J1. かま関係 (T-8421B) .....	17
J2. かま関係 (T-8422B) .....	21
J3. かま関係 .....	25
K. 下軸関係 .....	27
L. 給油潤滑関係 .....	29
M. 糸通し関係 .....	33
N. 糸巻関係 .....	35
P. 糸切り関係 .....	37
Q. 糸緩め関係 (T-8422B).....	41
R. 糸払い関係 (T-8422B) .....	43
S1. コントロールボックス、モータ関係.....	45
S2. コントロールボックス関係.....	47
T. 逆転スイッチ関係 .....	49
U. 電装品関係 .....	51
V. 電磁押え上げセット関係(オプション部品) .....	53
Z1. 付属品関係 .....	55
Z2. 付属品関係 .....	57
Wa. 警告ラベル .....	59
Sp. 仕様別部品一覧表 .....	60
Ga1. ゲージ一覧表 (T-8421B) .....	62
Ga2. ゲージ一覧表 (T-8422B) .....	69
索引 .....	73

## Notes for using this parts book

1. This book was prepared based on information available in November 2006.
2. Parts are subject to changes in design without prior notice.
3. Parts supplied as complete assemblies are circled by a dotted line.

## CONTENTS

A. Machine body .....	1
B. Upper shaft mechanism .....	3
C. Needle bar rocking mechanism .....	5
D. Presser foot mechanism .....	7
E. Feed mechanism .....	9
F. Quick reverse mechanism .....	11
G. Feed shaft mechanism .....	13
H. Gauge parts .....	15
J1. Rotary hook mechanism (T-8421B) .....	17
J2. Rotary hook mechanism (T-8422B) .....	21
J3. Rotary hook mechanism .....	25
K. Lower shaft mechanism .....	27
L. Lubrication .....	29
M. Threading mechanism .....	33
N. Bobbin winder mechanism .....	35
P. Thread trimmer mechanism .....	37
Q. Tension release mechanism (T-8422B).....	41
R. Thread wiper mechanism (T-8422B) .....	43
S1. Control box and motor mechanism .....	45
S2. Control box mechanism .....	47
T. Quick reverse switch mechanism .....	49
U. Power supply equipment mechanism .....	51
V. Presser foot lifting solenoid set mechanism (Option parts) ....	53
Z1. Accessories .....	55
Z2. Accessories .....	57
Wa. Warning labels .....	59
Sp. Different parts list .....	60
Ga1. Gauge parts list (T-8421B) .....	62
Ga2. Gauge parts list (T-8422B) .....	69
Index .....	73

A. 主体関係 / Machine body

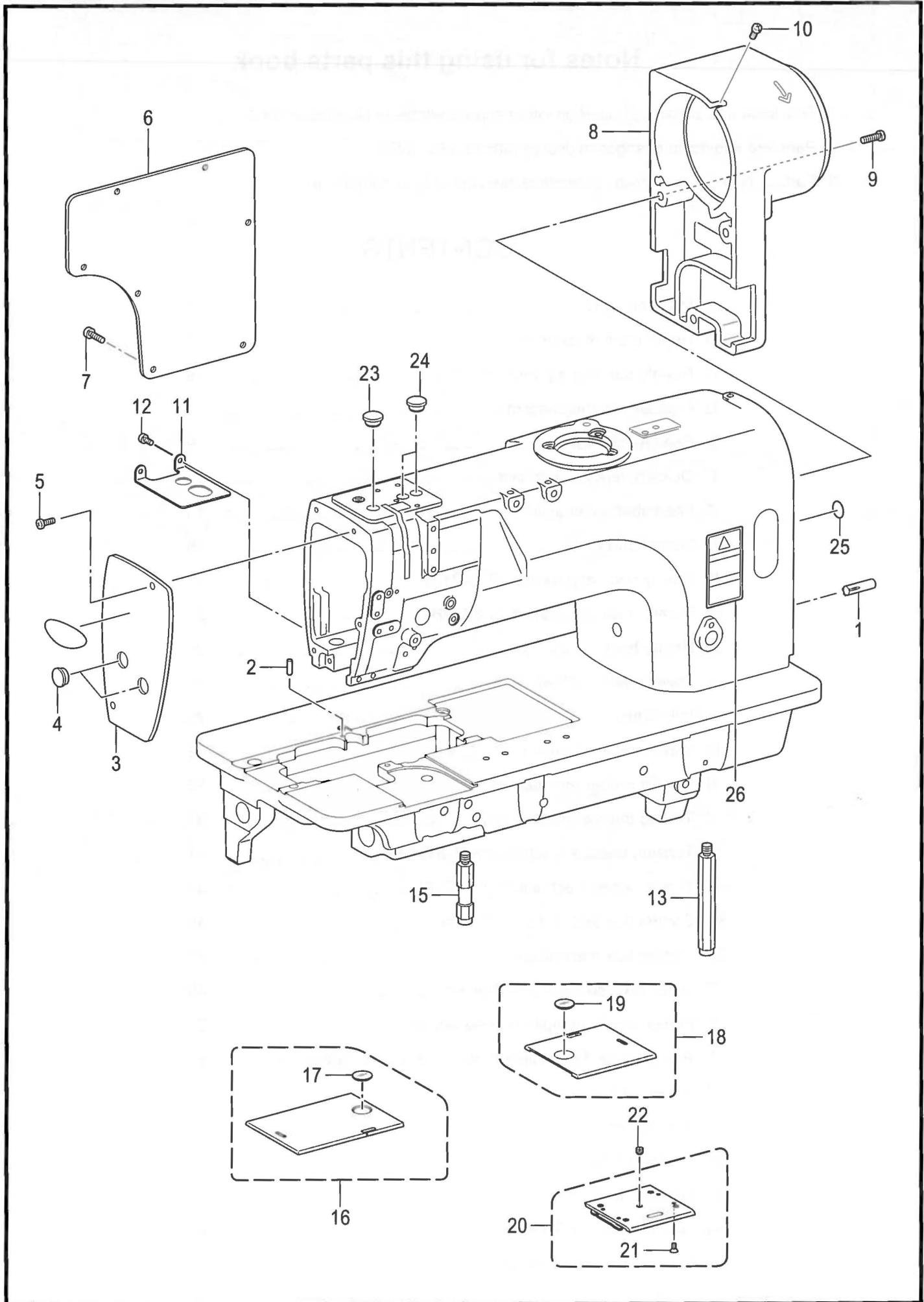

T-8421B/8422B-050

A . 主体関係 / Machine body

REF.NO	CODE	Q'TY	品名	NAME OF PARTS	RM
1	140063001	2	ミゾツキピン	DOWEL PIN	
2	SA3924001	1	ハリイタイチキメピン	POSITIONING PIN	
3	SA2440001	1	メンイタ	FACE PLATE	
4	SA2929001	2	ゴムセン12.5	RUBBER CAP, 12.5	
5	062500816	2	ナベコ5X8	SCREW PAN M5X8	
6	SA2441001	1	ガワイタ	REAR COVER	
7	062501216	7	ナベコ5X12	SCREW PAN M5X12	
8	SA2442101	1	モータカバー	MOTOR COVER	
9	062501416	3	ナベコ5X14	SCREW PAN M5X14	
10	062501016	1	ナベコ5X10	SCREW PAN M5X10	
11	SA2443101	1	ダストプレート	DUST PROTECTOR	
12	062500616	2	ナベコ5X6	SCREW PAN M5X6	
13	SA2444101	1	キヤクチュウL	BED LEG L	
15	SA2445101	1	キヤクチュウS	BED LEG S	
16	SA2447001	1	スベリイタLAクミ	SLIDE PLATE, LA ASSY	
17	SA2479001	1	スベリイタマド	BOBBIN WINDOW	
18	SA2449001	1	スベリイタRクミ	SLIDE PLATE ASSY, R	
19	SA2479001	1	スベリイタマド	BOBBIN WINDOW	
20	S36663051	1	スベリイタFクミ	SLIDE PLATE F ASSY	
21	S34438051	4	サラネジ3.18X4	SCREW, FLAT SM3.18-40X4	
22	116010001	1	トメネジ5.16	SET SCREW, SM5.16-40X4	
23	SA2929001	1	ゴムセン12.5	RUBBER CAP, 12.5	
24	SA2929001	2	ゴムセン12.5	RUBBER CAP, 12.5	
25	S37060001	1	アースマーク	LABEL, GROUNDING	
26	SA2040001	1	<中国向以外> ラベルチュウイ.フエイ	< Except for China > LABEL, CAUTION JPN/ENG	
26	SA2041001	1	<中国向> ラベルチュウイ.チュウエイ	< For China only > LABEL, CAUTION CHN/ENG	

B. 上軸関係 / Upper shaft mechanism

< 微量給油仕様 - □0□用 / For - □0□ Minimum lubrication type >

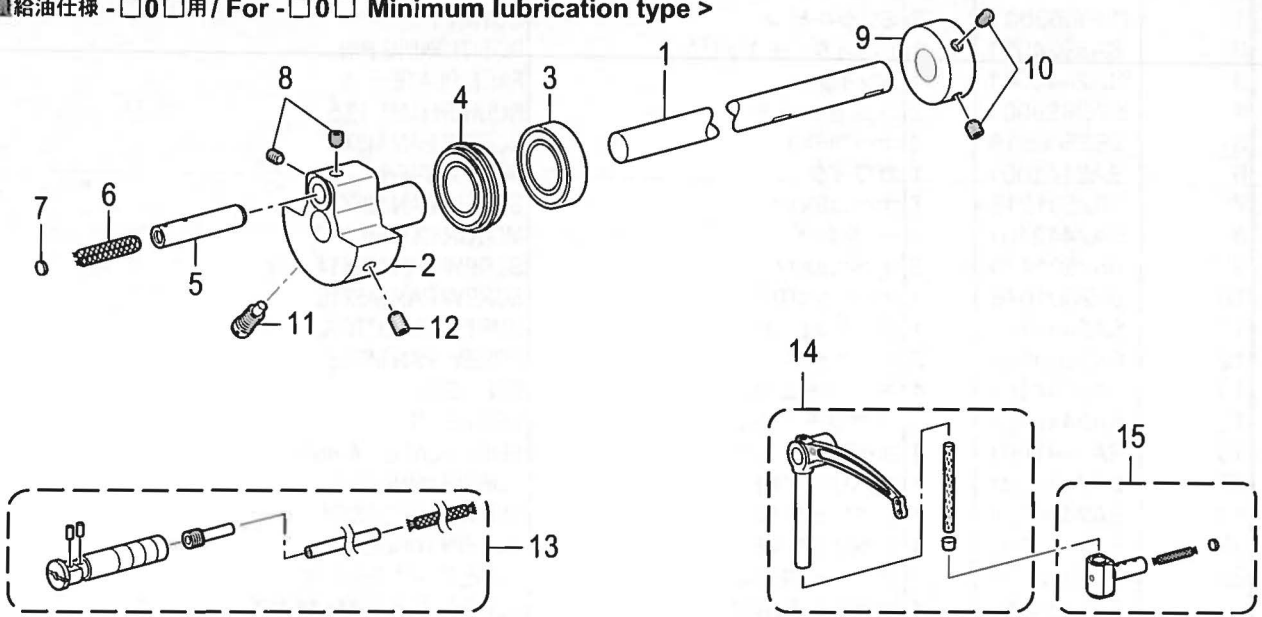

< セミドライ仕様 - □3□用 / For - □3□ Semi dry type >

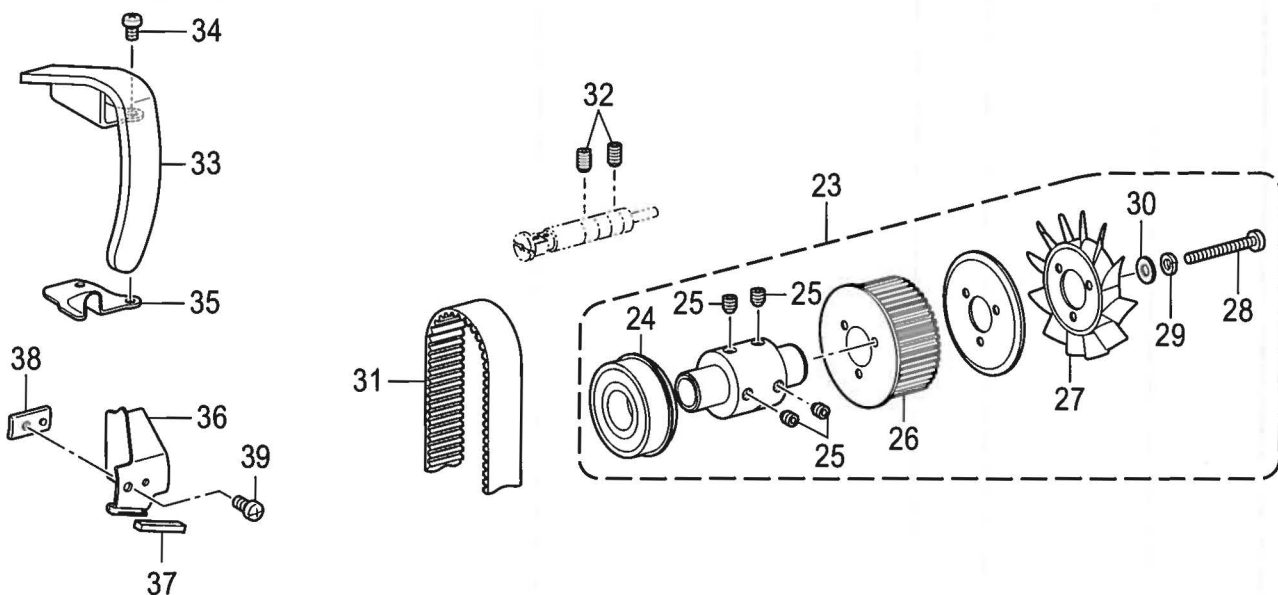
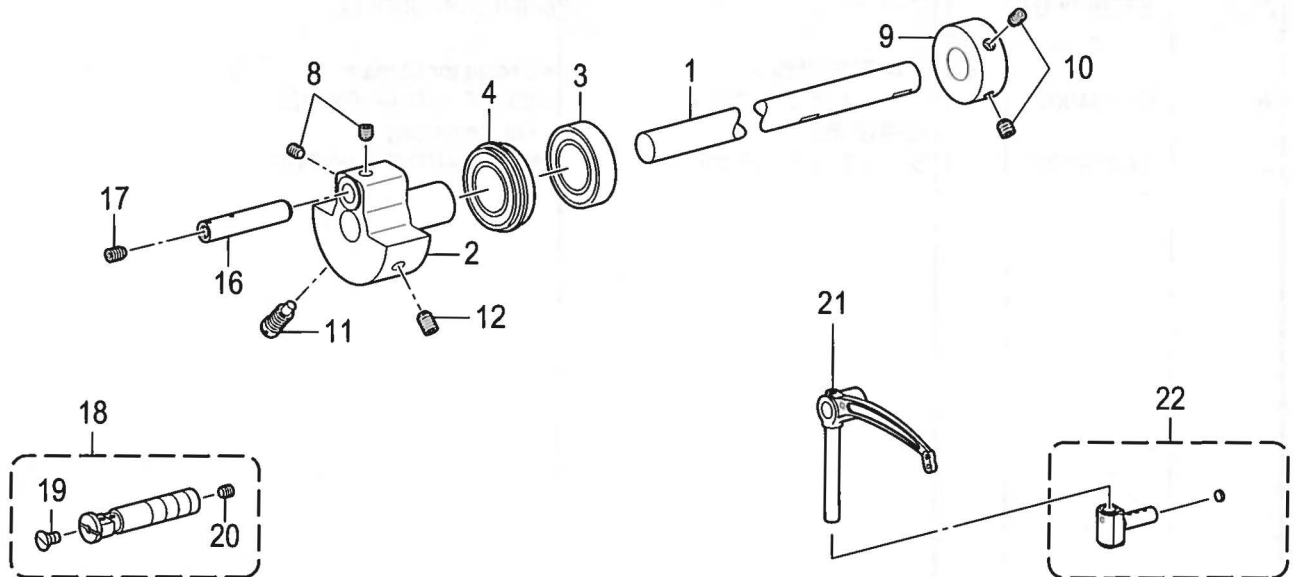



B. 上軸関係 / Upper shaft mechanism

REF.NO	CODE	Q'TY	品名	NAME OF PARTS	RM
			<-□0□用>	<For -□0□ >	
1	SA2452101	1	ウワジクDD	UPPER SHAFT, DD	
2	SA4089001	1	テンビークランク	THREAD TAKE-UP CRANK	
3	S25234001	1	タマジクウケ6004ZZ	BALL BEARING, 6004ZZ	
4	S38707001	1	タマジクウケ6004ZZNR	BALL BEARING, 6004ZZNR	
5	SA6166001	1	ハリボウクランクジク	CRANKSHAFT	
6	117006001	1	クミヒモ	WICK, L=60	
7	113014000	1	クミヒモフタ	PUSHER	
8	S25260001	2	アナヒラ6X5ホソメ	SET SCREW SOCKET (FT) M6X5	
9	SA1120001	1	イトマキクドウリン	BOBBIN WINDER DRIVING WHEEL	
10	S23651001	2	アナヒラ6X6ホソメ	SET SCREW SOCKET (FT) M6X6	
11	S25235001	1	シメネジ8	SCREW M8	
12	S25236001	1	アナヒラ6X10ホソメ	SET SCREW SOCKET (FT) M6X10	
13	SA2861101	1	テンビンササエジクソウクミ	THREAD TAKE-UP S-SHAFT UNIT	
			<-□03, -□0F用>	<For -□03, -□0F>	
14	SA2935101	1	テンビンS3-Lクミ	THREAD TAKE-UP LEVER ASSY, S3-L	
			<-□05用>	< For -□05>	
14	SA2936101	1	テンビンS5-Lクミ	THREAD TAKE-UP LEVER ASSY, S5-L	
			<-□0□用>	<For -□0□>	
15	S13160001	1	テンビンスベリコ2クミ	T-TAKE-UP SLIDE BLOCK ASSY, 2	
			<-□3□用>	<For -□3□>	
1	SA2452101	1	ウワジクDD	UPPER SHAFT, DD	
2	SA4089001	1	テンビークランク	THREAD TAKE-UP CRANK	
3	S25234001	1	タマジクウケ6004ZZ	BALL BEARING, 6004ZZ	
4	S38707001	1	タマジクウケ6004ZZNR	BALL BEARING, 6004ZZNR	
16	SA4112101	1	テンビークランクジクP	THREAD TAKE-UP CRANK SHAFT P	
17	012500536	1	アナヒラ5X5	SET SCREW SOCKET (FT) M5X5	
8	S25260001	2	アナヒラ6X5ホソメ	SET SCREW SOCKET (FT) M6X5	
9	SA1120001	1	イトマキクドウリン	BOBBIN WINDER DRIVING WHEEL	
10	S23651001	2	アナヒラ6X6ホソメ	SET SCREW SOCKET (FT) M6X6	
11	S25235001	1	シメネジ8	SCREW M8	
12	S25236001	1	アナヒラ6X10ホソメ	SET SCREW, SOCKET (FT) M6X10	
18	SA2464101	1	テンビンササエジククミ	THREAD TAKE-UP S-SHAFT ASSY	
19	SA2958001	1	サラネジ5X6	SCREW FLAT M5X6	
20	012500536	1	アナヒラ5X5	SET SCREW SOCKET (FT) M5X5	
			<-□33, -□3F用>	<For -□33, -□3F>	
21	SA4115101	1	テンビンS3P	THREAD TAKE-UP LEVER S3 P	
			<-□3□用>	<For -□3□>	
22	SA4129101	1	テンビンスベリコクミ	THREAD TAKE-UP SLIDE B-ASSY	
23	SA2460001	1	ツギテソウクミ	PRESSER ADJUSTING UNIT	
24	S38710001	1	タマジクウケ6204ZZNR	BALL BEARING, 6204ZZNR	
25	S23651001	4	アナヒラ6X6ホソメ	SET SCREW SOCKET (FT) M6X6	
26	SA2461001	1	タイミングプーリU DD	TIMING PULLEY, U DD	
27	S38713100	1	ファン	FAN	
28	062403512	3	ナベコ4X35	SCREW PAN M4X35	
29	028040242	3	バネザガネ2-4	WASHER SPRING 2-4	
30	025040232	3	ヒラザガネチュウ4	WASHER PLAIN M 4	
31	SA2463001	1	タイミングベルト	TIMING BELT	
32	012061036	2	アナヒラ6X10	SET SCREW SOCKET (FT) M6X10	
33	SA2469001	1	テンビンカバー	THREAD TAKE-UP LEVER COVER	
34	062500816	2	ナベコ5X8	SCREW PAN M5X8	
35	SA4537001	1	ダストカバー	DUST COVER	
36	SA3058101	1	シヤヘイバン	SHELTER PLATE	
37	SA3065001	1	フェルト	FELT	
38	SA3059101	1	シヤヘイバンオサエ	HOLDER, SHELTER PLATE	
39	062500816	1	ナベコ5X8	SCREW PAN M5X8	

C. 針棒揺動関係 / Needle bar rocking mechanism

< 微量給油仕様 - □0□用 / For - □0□ Minimum lubrication type >

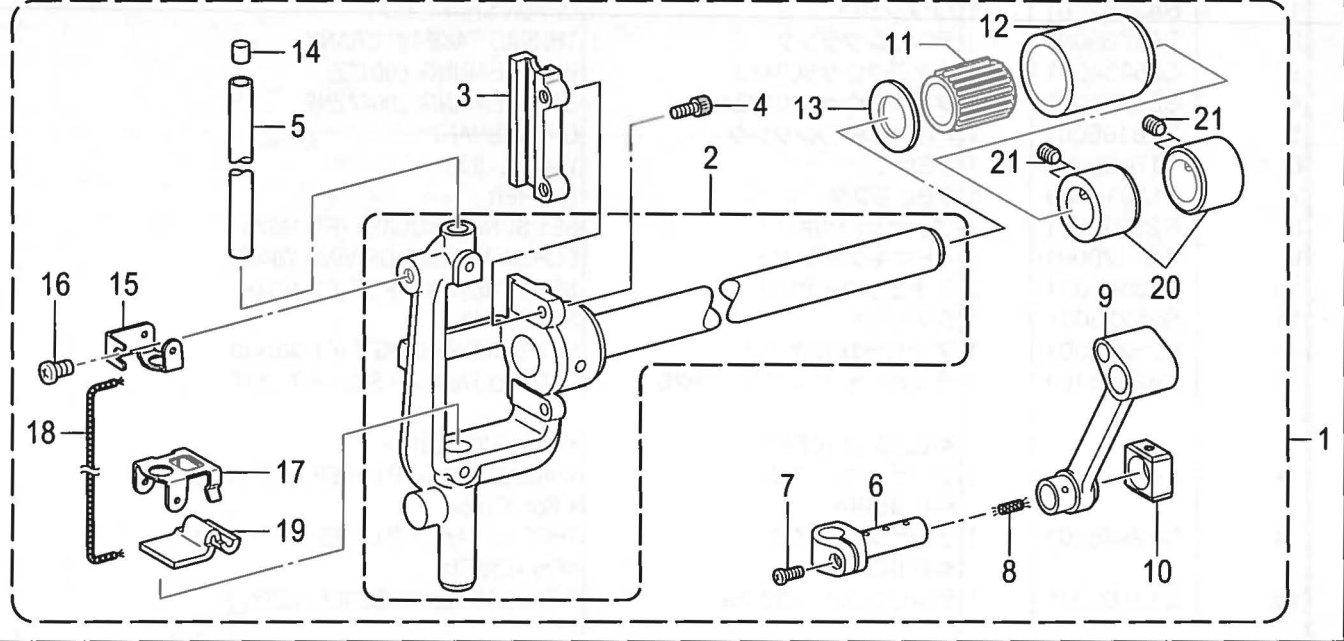

< セミドライ仕様 - □3□用 / For - □3□ Semi dry type >

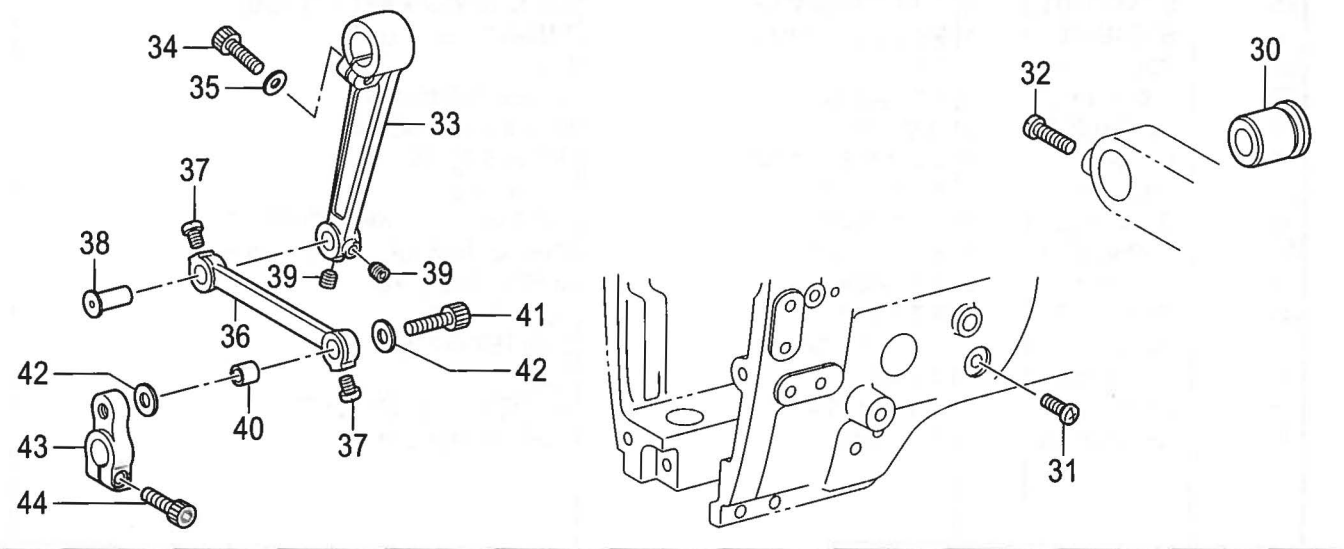
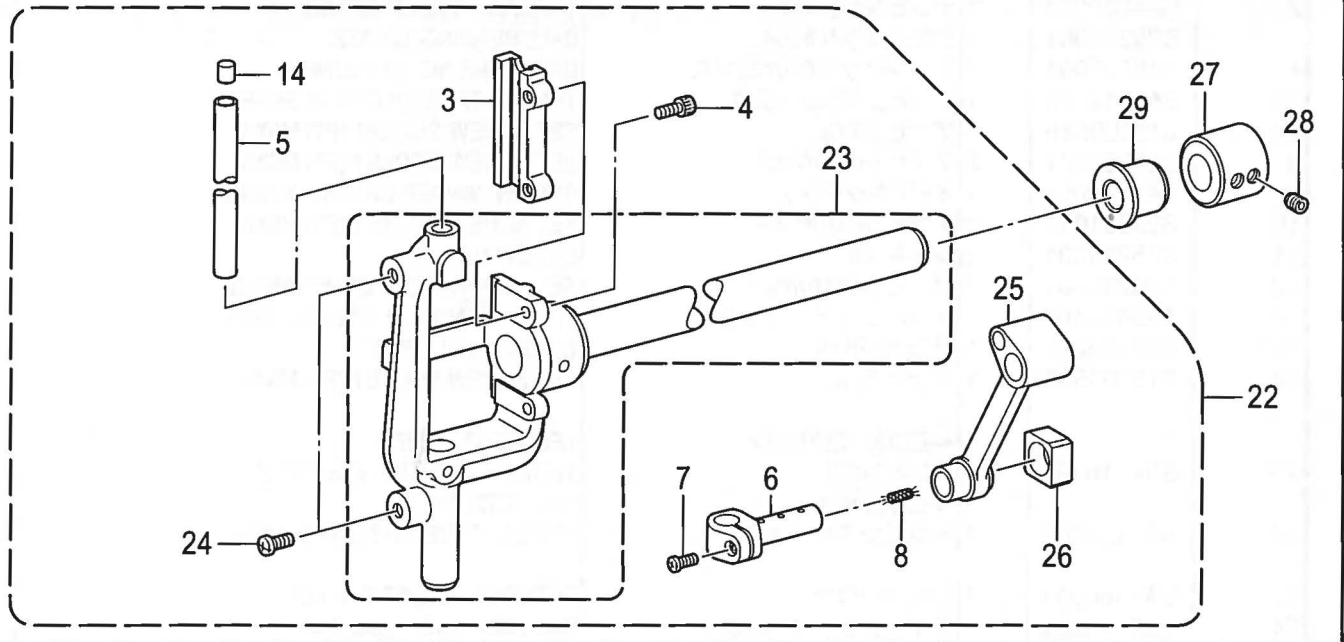

T-8421B/8422B-115

C. 針棒揺動関係 / Needle bar rocking mechanism

REF.NO	CODE	Q'TY	品名	NAME OF PARTS	RM
			<-□0□用>	<For - □0□>	
1	SA4124301	1	ハリボウヨウドウジクミ	NEEDLE BAR ROCKER SHAFT ASSY	
2	SA3854001	1	ハリボウダイクミ	NEEDLE BAR BASE ASSY	
3	SA2474201	1	カクコマスライダ	SLIDE BLOCK SLIDER	
4	018401036	2	アナボルト4X10	BOLT SOCKET M4X10	
5	SA2475101	1	ハリボウ	NEEDLE BAR	
6	SA3710001	1	ハリボウダキ	NEEDLE BAR CLAMP	
7	062350816	1	ナベコ35X8	SCREW PAN M3.5X8	
8	112728001	1	クミヒモ	WICK, L=50	
9	SA3711101	1	ハリボウクランクロッド	CRANK ROD, N-BAR	
10	SA3712001	1	カクコマ	SLIDE BLOCK	
11	SA2482001	1	ニードルベアリング	NEEDLE BEARING	
12	SA2483001	1	ケース	CASE	
13	SA2484001	1	ザガネ	WASHER, PLAIN	
14	148394000	1	ハリボウセン	CAP, N-BAR	
15	SA4007001	1	フェルトオサエU	FELT SUPPORT, U	
16	062500616	1	ナベコ5X6	SCREW, PAN M5X6	
17	SA3848001	1	フェルトオサエD	FELT SUPPORT, D	
18	S07465000	1	クミヒモ	WICK L=200	
19	SA3852001	1	フェルト	FELT	
20	SA2485001	2	セットカラ-	SET SCREW COLLAR	
21	S25260001	4	アナヒラ6X5ホソメ	SET SCREW SOCKET (FT) M6X5	
			<-□3□用>	<For - □3□>	
22	SA4093201	1	ハリボウヨウドウジクミ	NEEDLE BAR ROCKER SHAFT ASSY	
23	SA2471001	1	ハリボウダイクミ	NEEDLE BAR BASE ASSY	
24	062500816	2	ナベコ5X8	SCREW PAN M5X8	
3	SA2474201	1	カクコマスライダ	SLIDE BLOCK SLIDER	
4	018401036	2	アナボルト4X10	BOLT SOCKET M4X10	
5	SA2475101	1	ハリボウ	NEEDLE BAR	
6	SA3710001	1	ハリボウダキ	NEEDLE BAR CLAMP	
7	062350816	1	ナベコ35X8	SCREW PAN M3.5X8	
8	112728001	1	クミヒモ	WICK, L=50	
25	SA4094001	1	ハリボウクランクロッド	CRANK ROD, N-BAR	
26	SA2481001	1	カクコマ	SLIDE BLOCK	
14	148394000	1	ハリボウセン	CAP, N-BAR	
27	SA2485001	1	セットカラ-	SET SCREW COLLAR	
28	S25260001	2	アナヒラ6X5ホソメ	SET SCREW SOCKET (FT) M6X5	
29	SA4095001	1	ヨウドウジクメタルL	BUSH, L	
30	SA2486101	1	ヨウドウジクメタルR	BUSH, R	
31	062500816	1	ナベコ5X8	SCREW PAN M5X8	
32	062061616	1	ナベコ6X16	SCREW PAN M6X16	
33	SA2489001	1	ハリボウヨウドウレバ-	NEEDLE BAR ROCKER LEVER	
34	018062032	1	アナボルト6X20	BOLT SOCKET M6X20	
35	118735002	1	ザガネ	WASHER	
36	SA2490101	1	ハリボウヨウドウリンク	ROCKER LINK, N-BAR	
37	S23460001	2	ナベコ6X5	SCREW PAN M6X5	
38	SA4117001	1	ヨウドウリンクジクP	LINK SHAFT, N-BAR ROCKER P	
39	012060636	2	アナヒラ6X6	SET SCREW SOCKET (FT) M6X6	
40	SA4118001	1	ヨウドウリンクカラ-P	ZIGZAG LINK BUSH, P	
41	018062532	1	アナボルト6X25	BOLT SOCKET M6X25	
42	SA2493001	2	ザガネ	WASHER, PLAIN	
43	SA2494001	1	ハリボウヨウドウウデ	NEEDLE BAR ROCK ARM	
44	018062032	1	アナボルト6X20	BOLT SOCKET M6X20	

D. 押え関係 / Presser foot mechanism

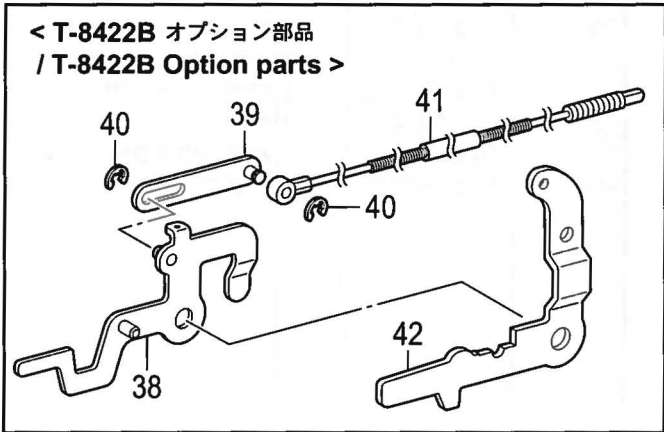
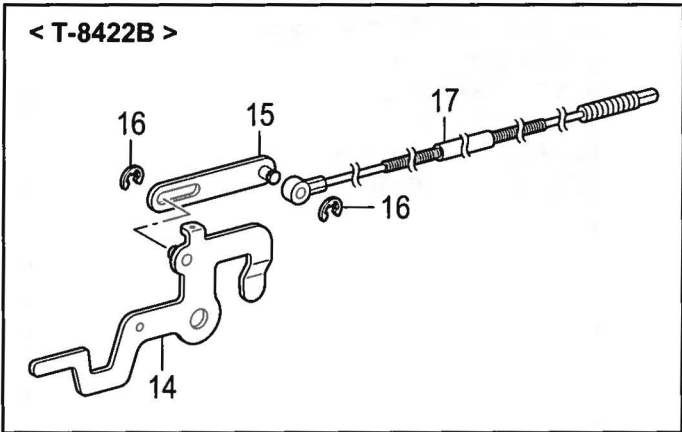
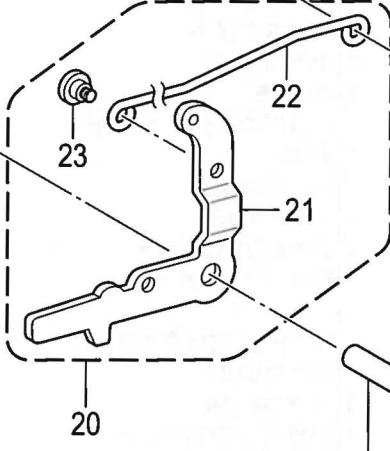
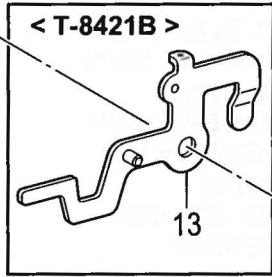
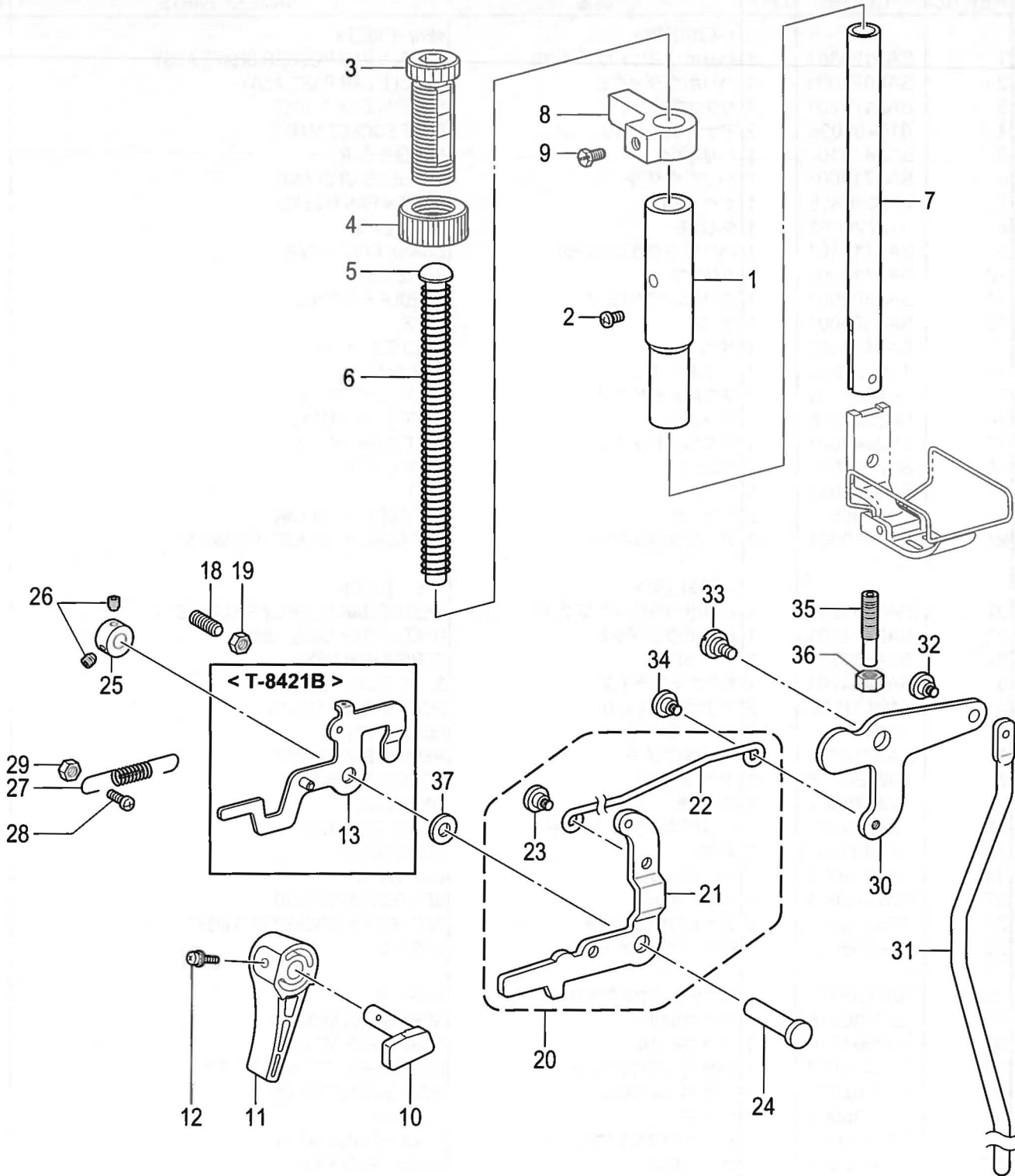

D . 押え関係 / Presser foot mechanism

REF.NO	CODE	Q'TY	品名	NAME OF PARTS	RM
1	SA2495001	1	オサエボウメタル	PRESSER BAR BUSH	
2	062500816	1	ナベコ5X8	SCREW PAN M5X8	
3	SA1174001	1	オサエチヨウセツネジM14	PRESSER ADJUSTING SCREW, M14	
4	SA1175001	1	チヨウセツネジナツトM14	ADJUST SCREW NUT	
5	SA7607001	1	オサエバネアンナイ	SPRING GUIDE	
			<-□□3, -□□5用>	<For -□□3, -□□5>	
6	S07346101	1	オサエバネ	PRESSER BAR SPRING, -5	
			<-□□F用>	<For -□□F>	
6	S16196001	1	オサエバネ	PRESSER BAR SPRING, F	
7	SA2496001	1	オサエボウ	PRESSER BAR	
8	SA2498001	1	オサエボウダキ	GUIDE BRACKET, P-BAR	
9	S25289001	1	ボルト6	BOLT (CP) M6X10	
10	SA2499001	1	オサエアゲクランク	PRESSER BAR LIFTING CRANK	
11	S31006001	1	オサエアゲテコ	LIFTING LEVER	
12	S39051001	1	ナベザクミ35X12	SCREW PAN (S/P W) M3.5X12	
			< T-8421B用 >	<For T-8421B >	
13	S07353001	1	イトユルメイタクミ	TENSION RELEASE PLATE ASSY	
			< T-8422B用 >	<For T-8422B >	
14	S07351001	1	イトユルメイタクミ	TENSION RELEASE PLATE ASSY	
15	S07529001	1	イトユルメレンカンクミ	T-RELEASE CONNECTING ROD ASSY	
16	048030342	2	トメワE3	RETAINING RING E3	
17	SA2677001	1	イトユルメワイヤー	TENSION RELEASE WIRE	
18	012061832	1	アナヒラ6X18	SET SCREW, SOCKET (FT) M6X18	
19	021060306	1	3シユナツト6	NUT 3 M6	
20	SA2500001	1	ヒザアゲレンカンクミ	KNEE LIFTER C-ROD ASSY	
21	SA2501001	1	オサエアゲレバー	PRESSER BAR LIFTING LEVER	
22	SA2502001	1	ヒザアゲレンカン	KNEE LIFTER CONNECTING ROD	
23	SA1179001	1	ダンネジ5	SHOULDER SCREW, M5	
24	S07349001	1	オサエアゲレバージク	P-BAR LIFTING LEVER SHAFT	
25	SA2504001	1	セツトカラ	SET SCREW COLLAR	
26	012500536	2	アナヒラ5X5	SET SCREW SOCKET (FT) M5X5	
			< T-8421B用 >	<For T-8421B >	
27	S07355051	1	オサエアゲレバーバネ	SPRING, EXTENSION	
			< T-8422B用 >	<For T-8422B >	
27	S07355051	2	オサエアゲレバーバネ	SPRING, EXTENSION	
28	062501216	1	ナベコ5X12	SCREW PAN M5X12	
29	021500106	1	1シユナツト5	NUT 1 M5	
30	SA2506001	1	ヒザアゲレバー	KNEE LIFTER LEVER	
31	SA2507001	1	ヒザアゲボウ	KNEE LIFTER BAR	
32	SA1179001	1	ダンネジ5	SHOULDER SCREW, M5	
33	SA2165001	1	ダンネジ6	SHOULDER SCREW, M6	
34	SA1179001	1	ダンネジ5	SHOULDER SCREW, M5	
35	SA4149101	1	チヨウセツネジ6	ADJUSTING SCREW 6	
36	021060306	1	3シユナツト6	NUT 3 M6	
37	S07350001	1	ザガネ	WASHER PLAIN	
			< T-8422B オプション部品 >	< T-8422B Option parts >	
38	S10780001	1	イトユルメイタクミ	TENSION RELEASE PLATE ASSY	
39	S07529001	1	イトユルメレンカンクミ	T-RELEASE CONNECTING ROD ASSY	
40	048030342	2	トメワE3	RETAINING RING E3	
41	SA2677001	1	イトユルメワイヤー	TENSION RELEASE WIRE	
42	SA2578001	1	オサエアゲレバー	PRESSER BAR LIFTING LEVER	

E. 送り関係 / Feed mechanism

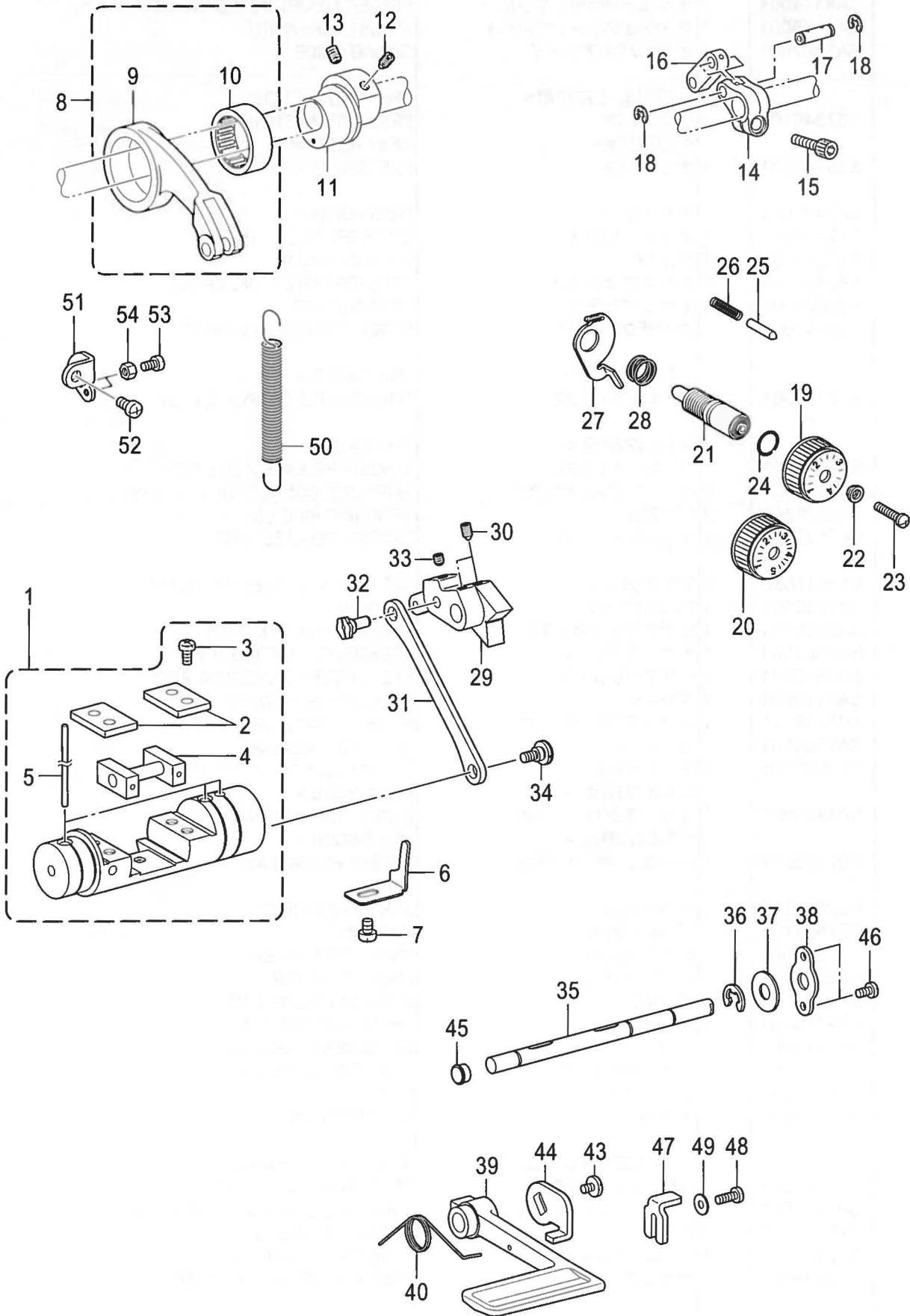

## E. 送り関係 / Feed mechanism

REF.NO	CODE	Q'TY	品名	NAME OF PARTS	RM
1	SA3062001	1	<-□□3, -□□F用> キリカエキ11クミ	<For -□□3, -□□F> FEED REGULATOR ASSY, 11	
1	SA2509001	1	<-□□5用> キリカエキクミ	<For -□□5> FEED REGULATOR ASSY	
2	SA2511001	2	カクコマアンナイタ	GUIDE PLATE	
3	062501016	4	ナベコ5X10	SCREW PAN M5X10	
4	SA2512001	1	キリカエキカクコマクミ	SLIDE BLOCK ASSY	
5	SA2515001	3	フェルト	FELT	
6	SA2516001	1	キリカエキトメ	STOPEER	
7	062060816	1	ナベコ6X8	SCREW PAN M6X8	
8	143611201	1	スイヘイオクリレンカンクミ	F-ROCKER CONNECTING ROD ASSY	
9	143612100	1	スイヘイオクリレンカン	FEED ROCKER CONNECTING ROD	
10	118954000	1	ニードルベアリング	NEEDLE BEARING	
11	SA2518001	1	スイヘイヘンシンリン5	LEVEL FEED ECCENTRIC WHEEL 5	
12	SA2585001	1	アナトガリ6X10ホソメ	SET SCREW, SOCKET (FT) M6	
13	S25236001	1	アナヒラ6X10ホソメ	SET SCREW SOCKET (FT) M6X10	
14	SA2521001	1	スイヘイオクリウデ5	FEED ROCKER ARM 5	
15	018062032	1	アナボルト6X20	BOLT SOCKET M6X20	
16	143613051	1	スイヘイオクリウデリンク	LINK	
17	143616001	1	スイヘイオクリウデジク	SHAFT	
18	048060342	2	トメワE6	RETAINING RING E6	
19	S38422001	1	<-□□3, -□□F用> オクリメモリダイヤル	<For -□□3, -□□F> STITCH LENGTH DIAL, 4	
20	S38427001	1	<-□□5用> オクリメモリダイヤル	<For -□□5> STITCH LENGTH DIAL, 5	
21	SA3056001	1	オクリチヨウセツネジ	FEED REGULATING STUD	
22	142746122	1	メモリイタオサエ	FEED REGULATING SUPPORTER	
23	129458202	1	シメネジ4.76	SCREW SM4.76	
24	108549001	1	Oリング	O RING	
25	S50098101	1	メモリイチギメピン	POSITIONING PIN	
26	100328001	1	メモリイチキメピンバネ	NOTCH SPRING	
27	SA2523001	1	ダイヤルロックレバー	DIAL LOCK LEVER	
28	S39830101	1	ダイヤルロックレバーバネ	SPRING	
29	SA2525001	1	オクリチヨウセツキ5	FEED REGULATOR 5	
30	016061031	2	アナトガリ6X10	SET SCREW SOCKET (CN) M6X10	
31	SA2526001	1	キリカエキレンカン	CONNECTING ROD	
32	SA2527001	1	ヘンシンジク	ECCENTRIC SHAFT	
33	012060636	1	アナヒラ6X6	SET SCREW SOCKET (FT) M6X6	
34	SA2528101	1	ダンネジ6	SHOULDER SCREW M6	
35	SA2529101	1	カエシヌイレバージクTR	SHAFT, R-LEVER TR	
36	048080342	1	トメワE8	RETAINING RING E8	
37	025100132	1	ヒラザガネシヨウ10	WASHER PLAIN S 10	
38	SA2530001	1	カンザ	SPACER	
45	104821001	1	ゴムセン10.5	RUBBER CAP, 10.5	
46	062500816	2	ナベコ5X8	SCREW PAN M5X8	
47	SA2532001	1	ハンドルストツパ	STOPPER	
48	062501216	1	ナベコ5X12	SCREW PAN M5X12	
49	025050236	1	ヒラザガネチユウ5	WASHER PLAIN M 5	
50	S07376001	1	キリカエキバネ	FEED REGULATOR SPRING	
51	SA2533001	1	バネカケ	SPRING HOOK	
52	062060816	1	ナベコ6X8	SCREW PAN M6X8	
53	062501216	1	ナベコ5X12	SCREW PAN M5X12	
54	021500106	1	1シユナツト5	NUT 1 M5	
39	S07374109	1	カエシヌイレバー	REVERSE STITCHING LEVER	
40	SA2531001	1	カエシヌイレバーオサエバネ	SPRING	
43	SA6592001	1	シメネジM5	SCREW M5	
44	SA2541001	1	カエシヌイレバーイタ	REVERSE STITCHING LEVER PLATE	

F . 逆転関係 / Quick reverse mechanism

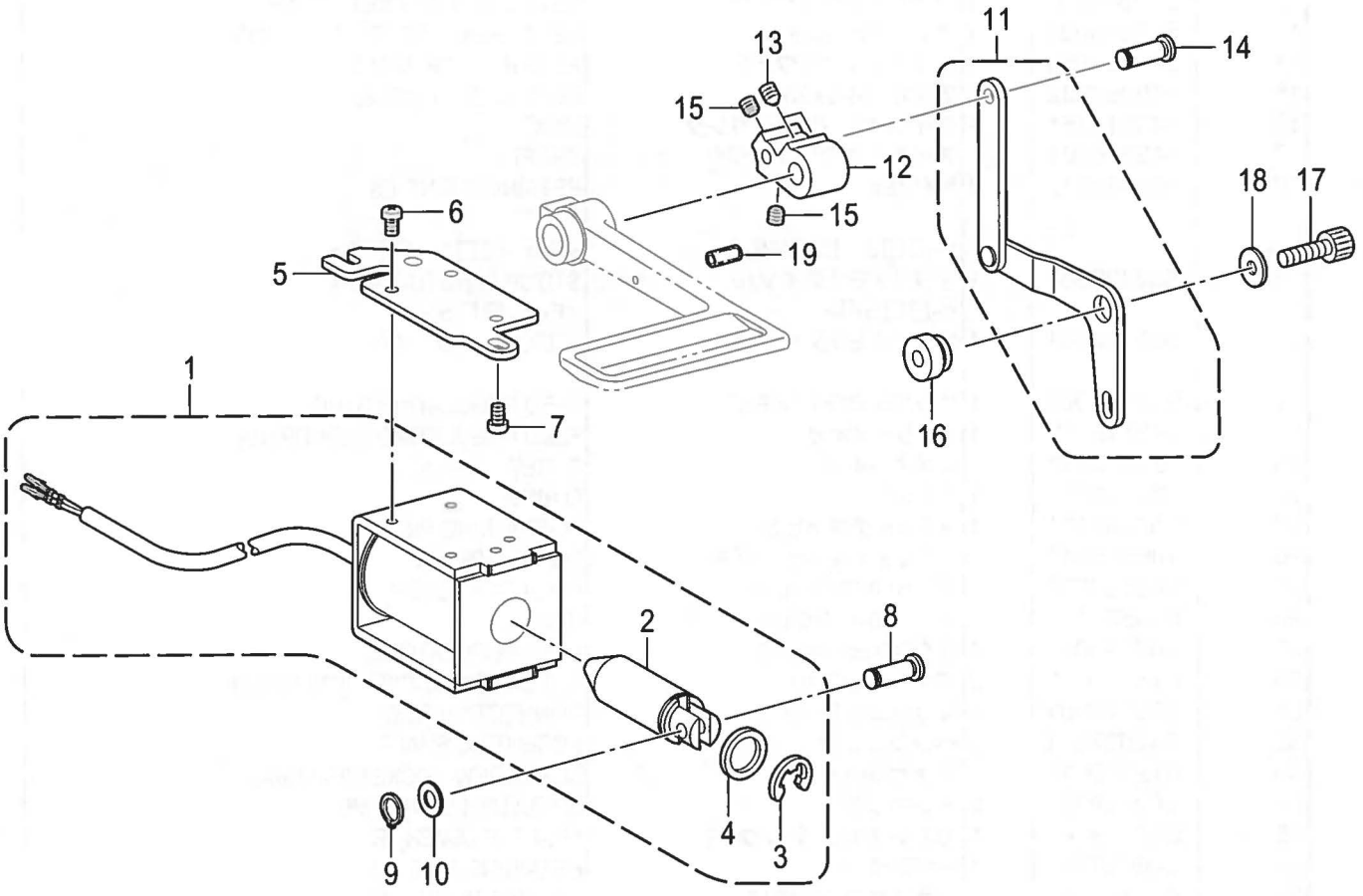



## F . 逆転関係 / Quick reverse mechanism

REF.NO	CODE	Q'TY	品名	NAME OF PARTS	RM
1	SA3072001	1	ギヤクテンソレノイドクミ	QUICK REVERSE SOLENOID ASSY	
2	154729001	1	プランジャ	PLUNGER	
3	154730001	1	トメワE15	RETAINING RING E15	
4	154731000	1	ゴムストツパー	RUBBER STOPPER	
5	SA2535101	1	ソレノイドドダイ	SOLENOID BRACKET	
6	062500812	3	ナベコ5X8	SCREW PAN M5X8	
7	062061016	2	ナベコ6X10	SCREW PAN M6X10	
8	SA2992001	1	レンケツピン	PIN	
9	048060142	1	トメワジクヨウC6	RETAINING RING EXTERNAL C6	
10	153138001	1	ザガネ	WASHER, PLAIN 6.5	
11	SA2536001	1	ソレノイドレバークミ	SOLENOID LEVER ASSY	
12	SA2540001	1	ギヤクテンレバー	QUICK REVERSE LEVER	
13	016061031	2	アナトガリ6X10	SET SCREW SOCKET (CN) M6X10	
14	SA2992001	1	レンケツピン	PIN	
15	012060636	2	アナヒラ6X6	SET SCREW SOCKET (FT) M6X6	
16	SA2539001	1	ソレノイドレバークミ	SOLENOID LEVER SHAFT	
17	018062032	1	アナボルト6X20	BOLT SOCKET M6X20	
18	149095001	1	ザガネ	WASHER, PLAIN 6	
19	153132000	1	ナイロンチューブ	NYLON TUBE, L=13.5	

G. 送り軸関係 / Feed shaft mechanism

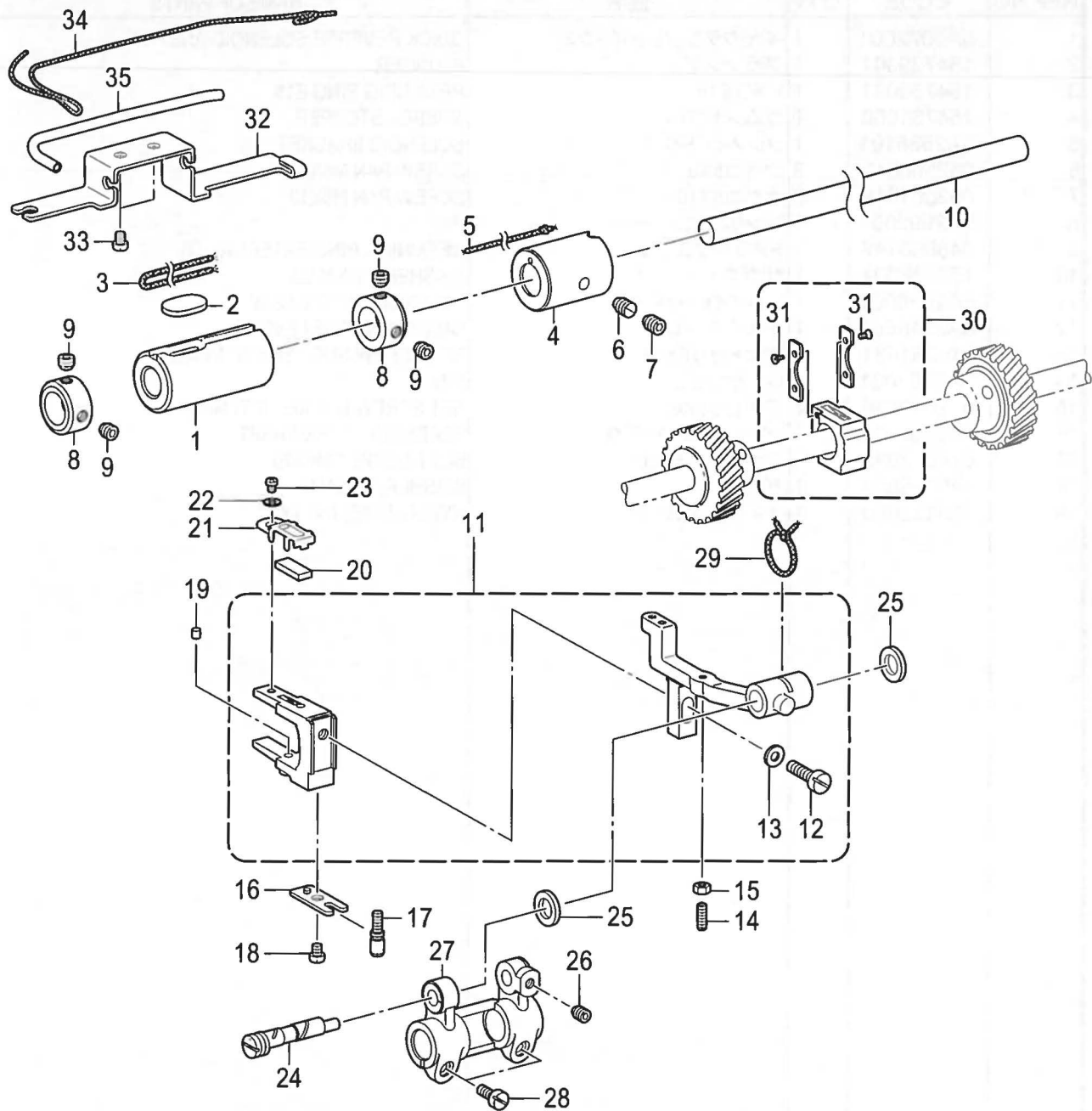

< オプション部品 / Option parts >

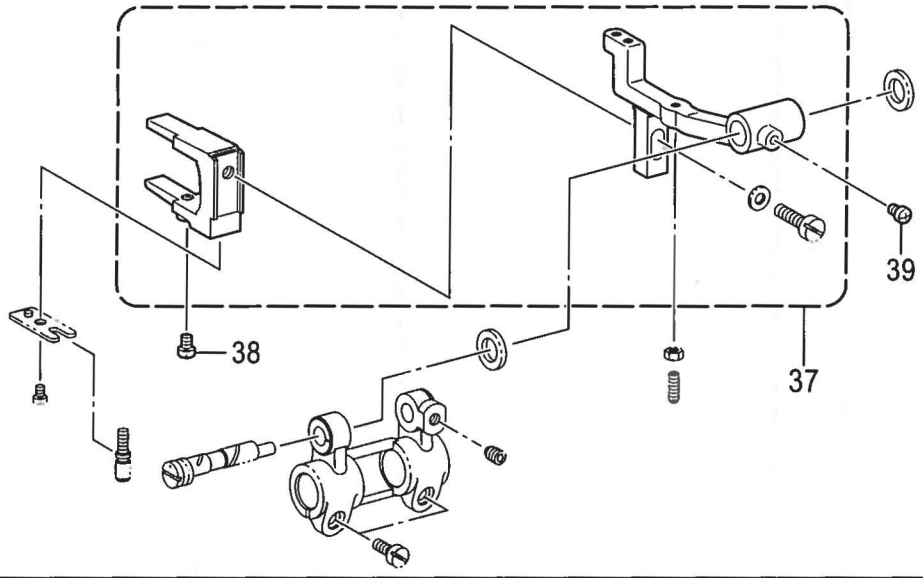

G . 送り軸関係 / Feed shaft mechanism

REF.NO	CODE	Q'TY	品名	NAME OF PARTS	RM
1	SA3855001	1	オクリジクメタルL	BUSH, L: F-ROCKER SHAFT	
2	SA3965001	1	フェルト	FELT	
3	SA4028001	1	クミヒモ4X4 L=220	WICK, 4X4 L=220	
4	SA2543001	1	オクリジクメタルR	FEED ROCKER SHAFT BUSH, R	
5	108802001	1	クミヒモ4X4	WICK, 4X4 L=250	
6	SA2544001	1	トメネジM6	SET SCREW M6	
7	012060636	1	アナヒラ6X6	SET SCREW SOCKET (FT) M6X6	
8	SA2546001	2	セツカラー	SET SCREW COLLAR	
9	S23651001	4	アナヒラ6X6ホソメ	SET SCREW SOCKET (FT) M6X6	
10	SA3840001	1	スイヘイオクリジク	FEED ROCKER SHAFT	
			< T-8421B用 >	<For T-8421B >	
11	SA6152101	1	オクリダイSTフタマタクミ	FEED BAR ST FORK ASSY	
			< T-8422B用 >	<For T-8422B >	
11	SA6150101	1	オクリダイTRフタマタクミ	FEED BAR TR FORK ASSY	
12	SA2927001	1	シメネジM6X14	SCREW, M6X14	
13	025060132	1	ヒラザガネシヨウ6	WASHER PLAIN S 6	
14	SA2566001	1	トメネジ3.5	SET SCREW, M3.5	
15	021350106	1	1シユナツツ35	NUT 1 M3.5	
16	SA2553001	1	フタマタプレート	FORKED PLATE	
17	SA2554001	1	タカサチヨウセツネジ	ADJUSTING SCREW, HIGHT	
18	062400616	1	ナベコ4X6	SCREW PAN M4X6	
19	SA3990001	1	フェルト	FELT	
20	SA3887001	1	フェルト	FELT	
21	SA3888001	1	フェルトオサエ	FELT HOLDER	
22	025030132	1	ヒラザガネシヨウ3	WASHER PLAIN S 3	
23	062300416	1	ナベコ3X4	SCREW PAN M3X4	
24	SA2550001	1	オクリダイトリツケジク	FEED BAR SHAFT	
25	SA2551001	2	スラストリング	THRUST RING	
26	012060636	1	アナヒラ6X6	SET SCREW SOCKET (FT) M6X6	
27	SA2555001	1	スイヘイオクリダイウデ	FEED ROCKER BASE ARM	
28	SA2928001	2	シメネジM5X12	SCREW, M5X12	
29	SA4538001	1	クミヒモ3X3 L=200	WICK 3X3 L=200	
30	SA2806001	1	オクリダイカクコマクミ	FEED BAR SLIDE BLOCK ASSY	
31	SA6308001	4	0サラコ3シユ2X4	SCREW FLAT #0 M2X4	
32	SA4009001	1	クミヒモササエ	WICK SUPPORT	
33	062400616	2	ナベコ4X6	SCREW PAN M4X6	
34	SA2724001	1	クミヒモ	WICK, L=400	
35	SA4011001	1	ビニルチューブ L=100	OIL TUBE, L=100	
			<オプション部品>ドライ仕様用	<Option parts> For dry type	
			< T-8421B用 >	<For T-8421B >	
37	SA6153101	1	オクリダイSTフタマタクミ	FEED BAR ST FORK ASSY	
			< T-8422B用 >	<For T-8422B >	
37	SA6151101	1	オクリダイTRフタマタクミ	FEED BAR TR FORK ASSY	
38	062500816	1	ナベコ5X8	SCREW PAN M5X8	
39	062500616	1	ナベコ5X6	SCREW PAN M5X6	

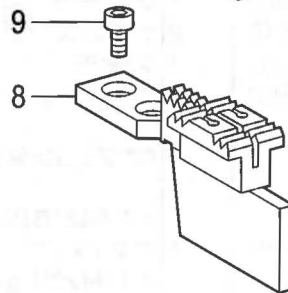
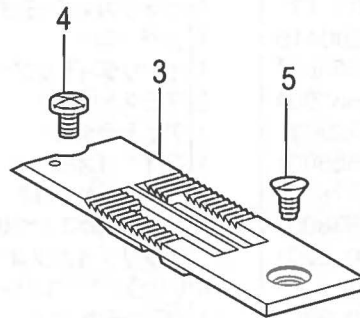
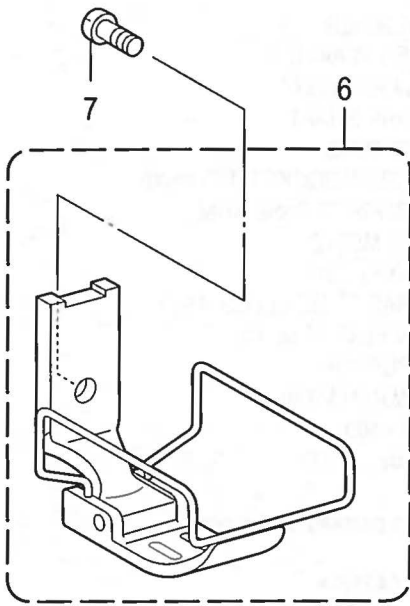
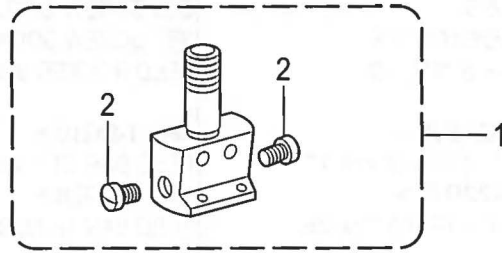

H . ゲージ関係 / Gauge parts

REF.NO	CODE	Q'TY	品名	NAME OF PARTS	RM
1	* P.62-72	1	ハリダキクミ	NEEDLE CLAMP ASSY	
2	116323001	2	シメネジ3.57	SCREW, SM3.57	
3	* P.62-72	1	ハリイタ	NEEDLE PLATE	
4	S11244001	1	シメネジ4.37 <-□□3, -□□5用>	SCREW, SM4.37 <For -□□3, -□□5>	
5	100032004	1	サラネジ4.37 <-□□F用>	SCREW, FLAT SM4.37-40X8 <For -□□F>	
5	117160001	1	サラネジ4.37	SCREW, FLAT SM4.37	
6	* P.62-72	1	オサエクミ	PRESSER FOOT ASSY	
7	113050001	1	シメネジ3.57	SCREW, SM3.57	
8	* P.62-72	1	オクリバ	FEED DOG	
9	S07494001	2	シメネジ3.18	SCREW, W/SOCKET SM3.18X7	

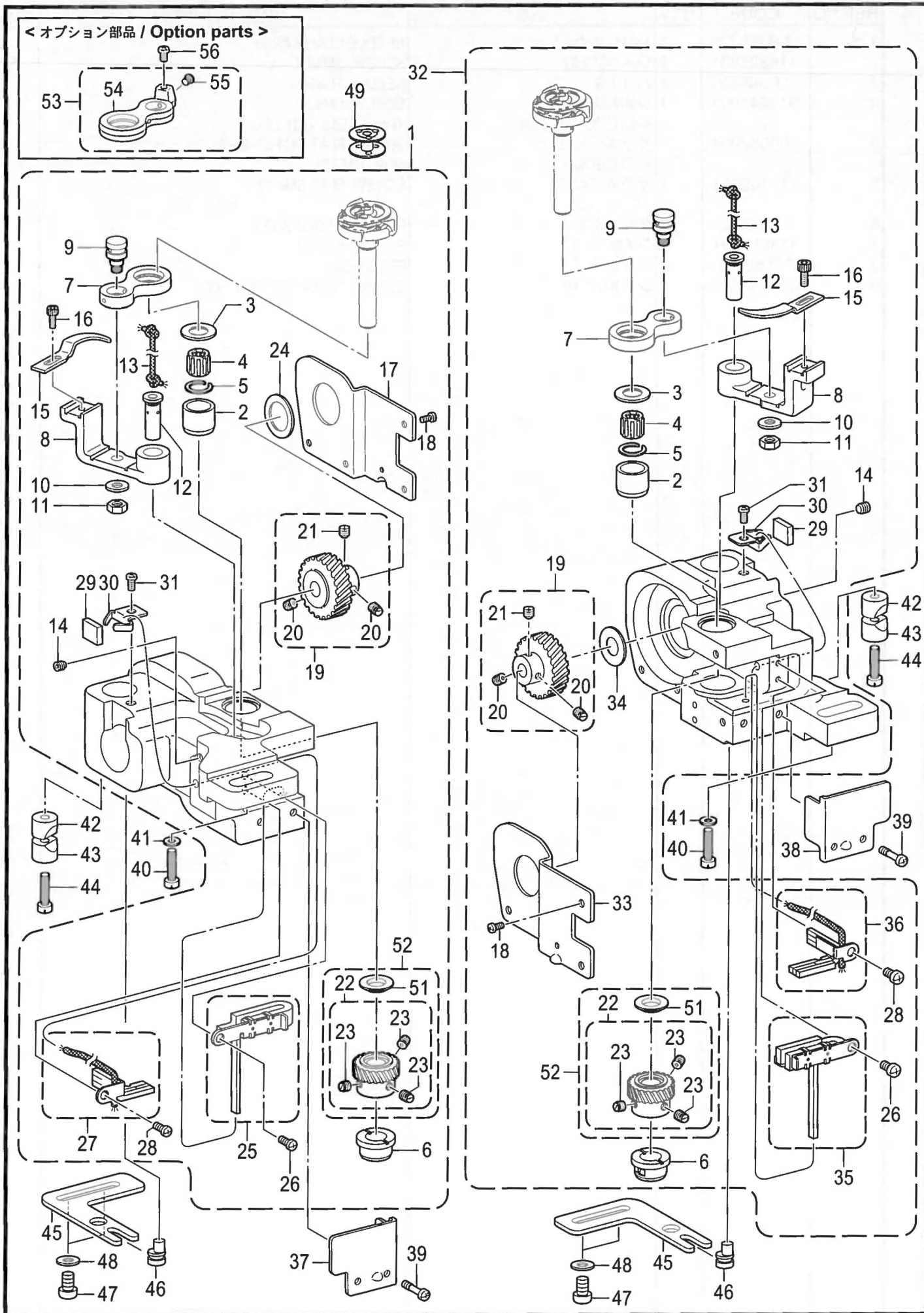

J1 . かま関係(T-8421B) / Rotary hook mechanism (T-8421B)

REF.NO	CODE	Q'TY	品名	NAME OF PARTS	RM
1	SA2755301	1	<-□□3, -□□F用> カマドダイ842ST(L)クミ	<For -□□3, -□□F> ROTARY HOOK BASE ASSY 842ST (L)	
1	SA2950301	1	<-□□5用> カマドダイ842ST-5Lクミ	<For -□□5> R-HOOK BASE ASSY 842ST-5 (L)	
2	SA4029001	1	カマジクメタルU	ROTARY HOOK SHAFT BUSH	
3	S09260001	1	スラストリングA <t=1.2>	THRUST RING, A: 1.2MM <t=1.2>	
3	SA4038001	1	スラストリング <t=1.0>	THRUST RING <t=1.0>	
3	S09261001	1	スラストリングB <t=1.4>	THRUST RING, B: 1.4MM <t=1.4>	
3	SA4444001	1	スラストリング0.8 <t=0.8>	THRUST RING 0.8MM <t=0.8>	
4	S07420000	1	ニードルベアリング	NEEDLE BEARING	
5	S07419001	1	ストツプリング	RETAINING RING	
6	SA6474001	1	カマジクメタルD	ROTARY HOOK SHAFT BUSH	
7	SA3856001	1	オプナーリンク	OPENER LINK	
8	SA3591001	1	オプナーレバー	OPENER LEVER	
9	SA2560001	1	オプナーリンクジク	SHAFT, O-LINK	
10	025710132	1	ヒラザガネシヨウ4.76	WASHER PLAIN S SM4.76	
11	021500316	1	3シュナット5	NUT 3 M5	
12	SA3889101	1	オプナーレバージク	O-LEVER SHAFT	
13	SA4026001	1	クミヒモ4X4 L=100	WICK, 4X4 L=100	
14	012501031	1	アナヒラ5X10	SET SCREW SOCKET (FT) M5X10	
15	S38212001	1	オプナー	OPENER	
16	154965001	1	アナボルト3.57X8	BOLT, SOCKET SM3.57X8	
17	SA2562201	1	カマドダイカバーL	ROTARY HOOK BASE COVER L	
18	062300612	4	ナベコ3X6	SCREW PAN M3X6	
19	SA2572001	1	スパイラルギア ネジツキ	SPIRAL GEAR SCREW ASSY	
20	SA2574001	2	トメネジM6ホソメ	SET SCREW, (FT) M6	
21	SA2575001	1	トメネジM6ホソメ	SET SCREW, (FT) M6	
22	SA6301001	1	ピニオン ネジツキ	PINION GEAR SCREW ASSY	
23	SA2574001	3	トメネジM6ホソメ	SET SCREW, (FT) M6	
24	SA3054001	1	スラストザガネL	THRUST WASHER, L	
25	SA6424101	1	フェルトULクミ	FELT UL ASSY	
26	062400616	1	ナベコ4X6	SCREW PAN M4X6	
27	SA4044001	1	フェルトDLクミ	FELT DL ASSY	
28	062400616	1	ナベコ4X6	SCREW PAN M4X6	
29	SA4012001	1	フェルト	FELT	
30	SA3894001	1	フェルトオサエ	FELT SUPPORT	
31	062400616	1	ナベコ4X6	SCREW PAN M4X6	
51	SA6294101	1	スラストリング	THRUST RING	
52	SA6307101	1	ピニオンセット	PINION GEAR SET	
32	SA2757301	1	<-□□3, -□□F用> カマドダイ842ST(R)クミ	<For -□□3, -□□F> ROTARY HOOK BASE ASSY 842ST (R)	
32	SA2951301	1	<-□□5用> カマドダイ842ST-5Rクミ	<For -□□5> R-HOOK BASE ASSY 842ST-5 (R)	
2	SA4029001	1	カマジクメタルU	ROTARY HOOK SHAFT BUSH	
3	S09260001	1	スラストリングA <t=1.2>	THRUST RING, A: 1.2MM <t=1.2>	
3	SA4038001	1	スラストリング <t=1.0>	THRUST RING <t=1.0>	
3	S09261001	1	スラストリングB <t=1.4>	THRUST RING, B: 1.4MM <t=1.4>	
3	SA4444001	1	スラストリング0.8 <t=0.8>	THRUST RING 0.8MM <t=0.8>	
4	S07420000	1	ニードルベアリング	NEEDLE BEARING	
5	S07419001	1	ストツプリング	RETAINING RING	
6	SA6474001	1	カマジクメタルD	ROTARY HOOK SHAFT BUSH	
7	SA3856001	1	オプナーリンク	OPENER LINK	
8	SA3591001	1	オプナーレバー	OPENER LEVER	
9	SA2560001	1	オプナーリンクジク	SHAFT, O-LINK	
10	025710132	1	ヒラザガネシヨウ4.76	WASHER PLAIN S SM4.76	
11	021500316	1	3シュナット5	NUT 3 M5	
12	SA3889101	1	オプナーレバージク	O-LEVER SHAFT	
13	SA4026001	1	クミヒモ4X4 L=100	WICK, 4X4 L=100	
14	012501031	1	アナヒラ5X10	SET SCREW SOCKET (FT) M5X10	
15	S38212001	1	オプナー	OPENER	

J1 . かま関係 (T-8421B) / Rotary hook mechanism (T-8421B)

< オプション部品 / Option parts >

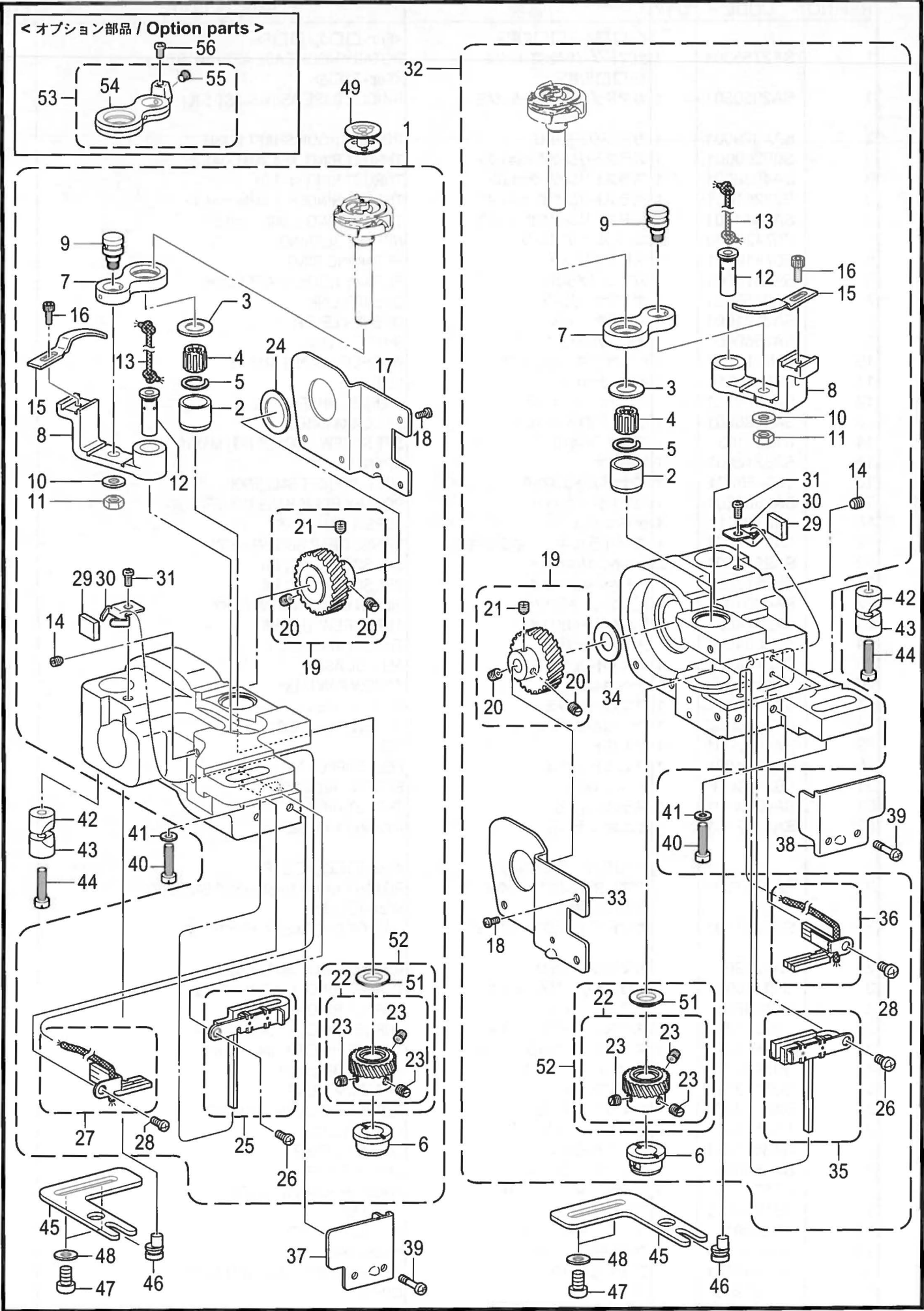

T-8421B-301



J1 . かま関係(T-8421B) / Rotary hook mechanism (T-8421B)

REF.NO	CODE	Q'TY	品名	NAME OF PARTS	RM
16	154965001	1	アナボルト3.57X8	BOLT, SOCKET SM3.57X8	
33	SA2563301	1	カマダイカバー-R	ROTARY HOOK BASE COVER R	
18	062300612	4	ナベコ3X6	SCREW PAN M3X6	
19	SA2572001	1	スパイラルギア ネジツキ	SPIRAL GEAR SCREW ASSY	
20	SA2574001	2	トメネジM6ホソメ	SET SCREW, (FT) M6	
21	SA2575001	1	トメネジM6ホソメ	SET SCREW, (FT) M6	
22	SA6301001	1	ピニオン ネジツキ	PINION GEAR SCREW ASSY	
23	SA2574001	3	トメネジM6ホソメ	SET SCREW, (FT) M6	
34	SA2579001	1	スラストザガネ	SPECER	
35	SA6425101	1	フェルトURクミ	FELT UR ASSY	
26	062400616	1	ナベコ4X6	SCREW PAN M4X6	
36	SA4045001	1	フェルトDRクミ	FELT DR ASSY	
28	062400616	1	ナベコ4X6	SCREW PAN M4X6	
29	SA4012001	1	フェルト	FELT	
30	SA3894001	1	フェルトオサエ	FELT SUPPORT	
31	062400616	1	ナベコ4X6	SCREW PAN M4X6	
51	SA6294101	1	スラストリング	THRUST RING	
52	SA6307101	1	ピニオンセット	PINION GEAR SET	
37	SA6462001	1	カマダイカバー-FL	ROTARY HOOK BASE COVER FL	
38	SA6463001	1	カマダイカバー-FR	ROTARY HOOK BASE COVER FR	
39	SA6417001	4	シメネジM4X12	SCREW M4X12	
40	SA2556001	2	シメネジM6X25	SCREW, M6X25	
41	115947101	2	ザガネ	WASHER PLAIN 6.35	
42	SA2722001	2	ピンチスリーブA	PINCH SLEEVE A	
43	SA2565001	2	ピンチスリーブB	PINCH SLEEVE B	
44	SA2556001	2	シメネジM6X25	SCREW, M6X25	
45	SA2567001	2	ハリスキチヨウセツイタ	NEEDLE UPPER ADJUSTING PLATE	
46	SA2568001	2	ハリスキチヨウセツジク	NEEDLE UPPER POSITIONING SHAFT	
47	062061016	4	ナベコ6X10	SCREW PAN M6X10	
48	025060136	4	ヒラザガネショウ6	WASHER PLAIN S 6	
49	S01928151	2	ボビン	BOBBIN	
			<オプション部品> ドライ仕様用	<Option parts> For dry type	
53	SA2827001	2	オープナーリンククミ	OPENER LINK ASSY	
54	SA2558001	2	オープナーリンク	OPENER LINK	
55	S58900000	2	セイミツネジM2	SCREW M2	
56	062400416	2	ナベコ4X4	SCREW, PAN M4X4	

< オプション部品 / Option parts >

65, 66, 67, 68

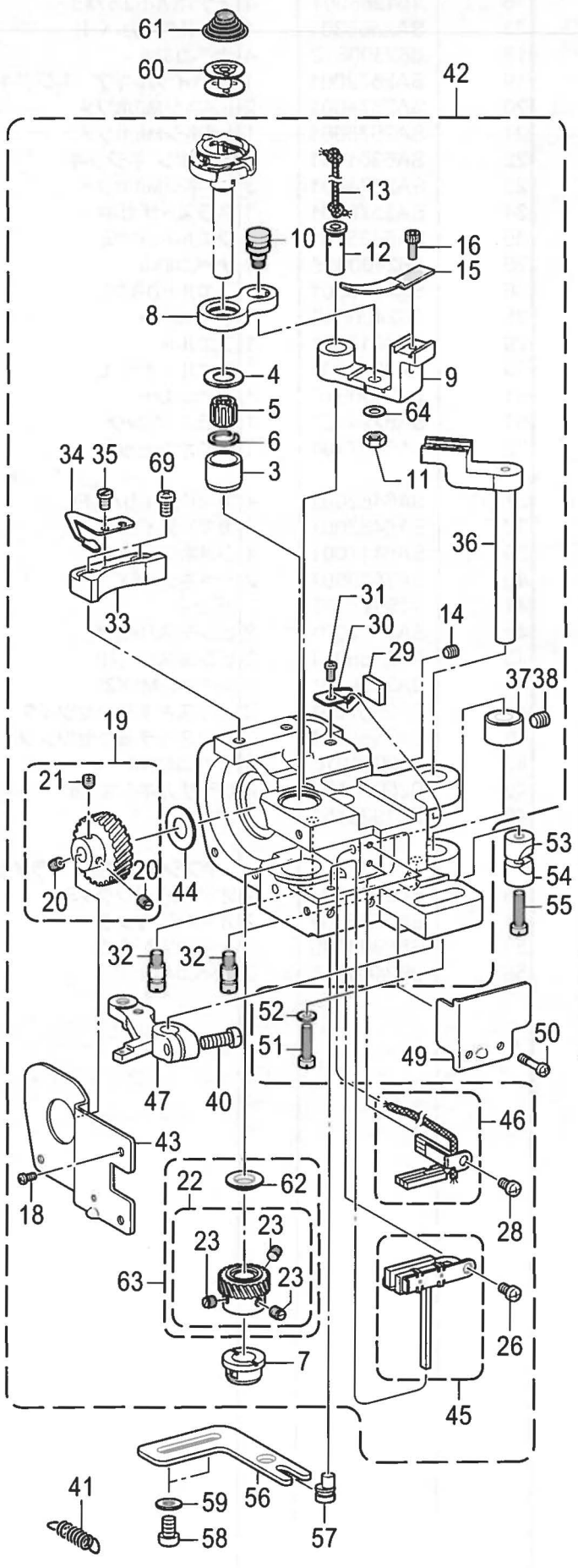
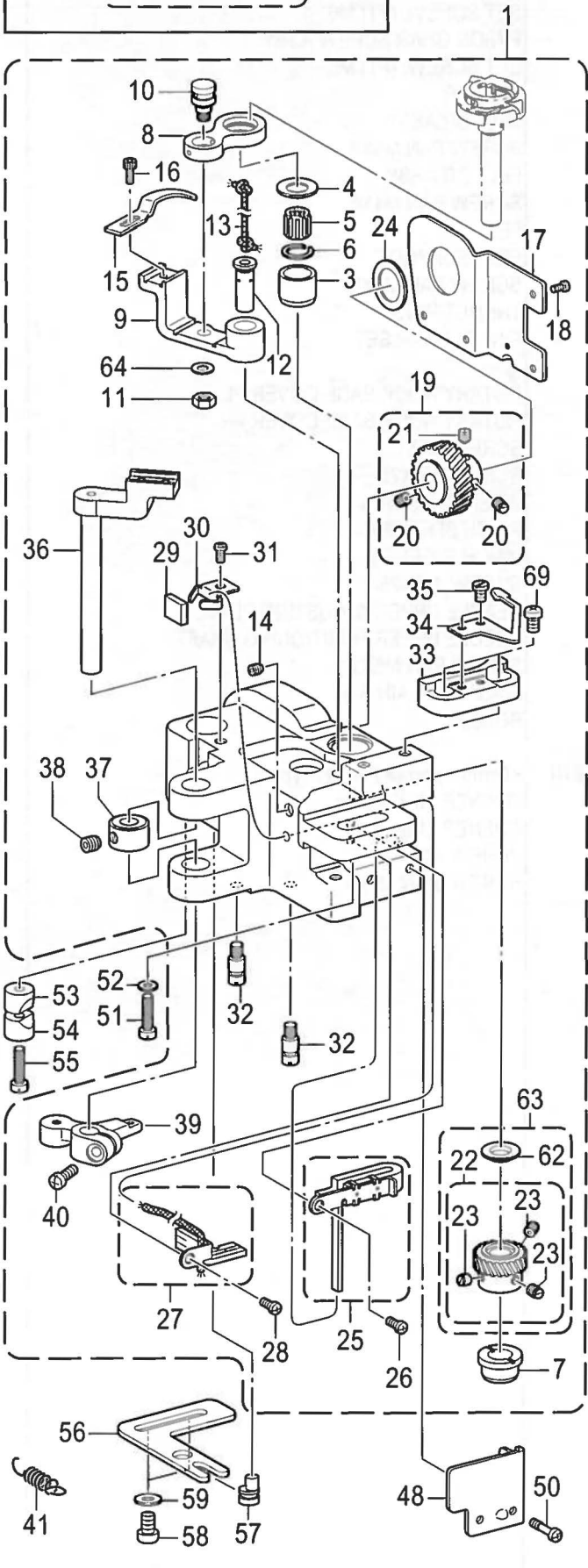

J2 . かま関係(T-8422B) / Rotary hook mechanism (T-8422B)

REF.NO	CODE	QTY	品名	NAME OF PARTS	RM
1	SA2714401	1	カマドダイ842イトキリLクミ	ROTARY HOOK BASE ASSY 842TR (L)	
3	SA4029001	1	カマジクメタルU	ROTARY HOOK SHAFT BUSH	
4	S09260001	1	スラストリングA< t=1.2 >	THRUST RING, A: 1.2MM < t=1.2 >	
4	SA4038001	1	スラストリング< t=1.0 >	THRUST RING < t=1.0 >	
4	S09261001	1	スラストリングB< t=1.4 >	THRUST RING, B: 1.4MM < t=1.4 >	
4	SA4444001	1	スラストリング0.8< t=0.8 >	THRUST RING 0.8MM < t=0.8 >	
5	S07420000	1	ニードルベアリング	NEEDLE BEARING	
6	S07419001	1	ストツブリング	RETAINING RING	
7	SA6474001	1	カマジクメタルD	ROTARY HOOK SHAFT BUSH	
8	SA3856001	1	オープナーリンク	OPENER LINK	
9	SA3859001	1	オープナーレバー	OPENER LEVER	
10	SA2560001	1	オープナーリンクジク	SHAFT, O-LINK	
11	021500316	1	3シュナツト5	NUT 3 M5	
12	SA3889101	1	オープナーレバージク	O-LEVER SHAFT	
13	SA4026001	1	クミヒモ4X4 L=100	WICK, 4X4 L=100	
14	012501031	1	アナヒラ5X10	SET SCREW SOCKET (FT) M5X10	
15	S38212001	1	オープナー	OPENER	
16	154965001	1	アナボルト3.57X8	BOLT, SOCKET SM3.57X8	
17	SA2562201	1	カマドダイカバーL	ROTARY HOOK BASE COVER L	
18	062300612	4	ナベコ3X6	SCREW PAN M3X6	
19	SA2572001	1	スパイラルギヤ ネジツキ	SPIRAL GEAR SCREW ASSY	
20	SA2574001	2	トメネジM6ホソメ	SET SCREW, (FT) M6	
21	SA2575001	1	トメネジM6ホソメ	SET SCREW, (FT) M6	
22	SA6301001	1	ピニオン ネジツキ	PINION GEAR SCREW ASSY	
23	SA2574001	3	トメネジM6ホソメ	SET SCREW, (FT) M6	
24	SA3054001	1	スラストザガネL	THRUST WASHER, L	
25	SA6424101	1	フェルトULクミ	FELT UL ASSY	
26	062400616	1	ナベコ4X6	SCREW PAN M4X6	
27	SA4044001	1	フェルトDLクミ	FELT DL ASSY	
28	062400616	1	ナベコ4X6	SCREW PAN M4X6	
29	SA4012001	1	フェルト	FELT	
30	SA3894001	1	フェルトオサエ	FELT SUPPORT	
31	062400616	1	ナベコ4X6	SCREW PAN M4X6	
32	SA2717001	2	ストツパネジ	STOPPER SCREW	
33	SA2676001	1	イドウハウケ	MOVABLE KNIFE BRACKET	
69	062400812	2	ナベコ4X8	SCREW PAN M4X8	
34	S07525100	1	シタイトホジバネ	SPRING PLATE	
35	141544001	2	シメネジ3.18	SCREW, SM3.18-40X3	
36	SA3912001	1	イドウハレバー	MOVABLE KNIFE LEVER	
37	SA2675001	1	セツトカラ	SET SCREW COLLAR	
38	S23651001	1	アナヒラ6X6ホソメ	SET SCREW SOCKET (FT) M6X6	
39	SA2671001	1	イトキリレバーL	THREAD TRIMMER LEVER, L	
40	062501212	1	ナベコ5X12	SCREW PAN M5X12	
62	SA6294101	1	スラストリング	THRUST RING	
63	SA6307101	1	ピニオンセツト	PINION GEAR SET	
64	025710132	1	ヒラザガネシヨウ4.76	WASHER PLAIN S SM4.76	
42	SA2718401	1	カマドダイ842イトキリRクミ	ROTARY HOOK BASE ASSY 842TR (R)	
3	SA4029001	1	カマジクメタルU	ROTARY HOOK SHAFT BUSH	
4	S09260001	1	スラストリングA< t=1.2 >	THRUST RING, A: 1.2MM < t=1.2 >	
4	SA4038001	1	スラストリング< t=1.0 >	THRUST RING < t=1.0 >	
4	S09261001	1	スラストリングB< t=1.4 >	THRUST RING, B 1.4MM < t=1.4 >	
4	SA4444001	1	スラストリング0.8< t=0.8 >	THRUST RING 0.8MM < t=0.8 >	
5	S07420000	1	ニードルベアリング	NEEDLE BEARING	
6	S07419001	1	ストツブリング	RETAINING RING	
7	SA6474001	1	カマジクメタルD	ROTARY HOOK SHAFT BUSH	
8	SA3856001	1	オープナーリンク	OPENER LINK	
9	SA3859001	1	オープナーレバー	OPENER LEVER	
10	SA2560001	1	オープナーリンクジク	SHAFT, O-LINK	
11	021500316	1	3シュナツト5	NUT 3 M5	
12	SA3889101	1	オープナーレバージク	O-LEVER SHAFT	
13	SA4026001	1	クミヒモ4X4 L=100	WICK, 4X4 L=100	
14	012501031	1	アナヒラ5X10	SET SCREW SOCKET (FT) M5X10	

T-8422B-301

< オプション部品 / Option parts >

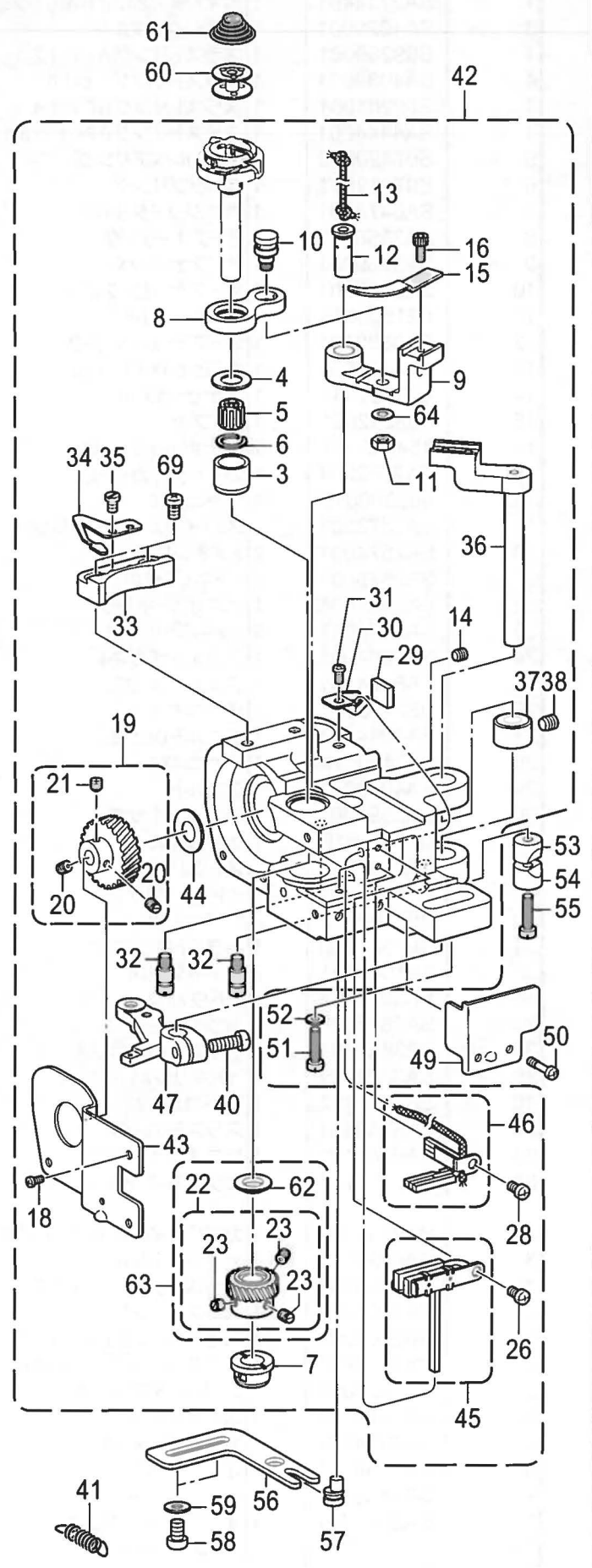
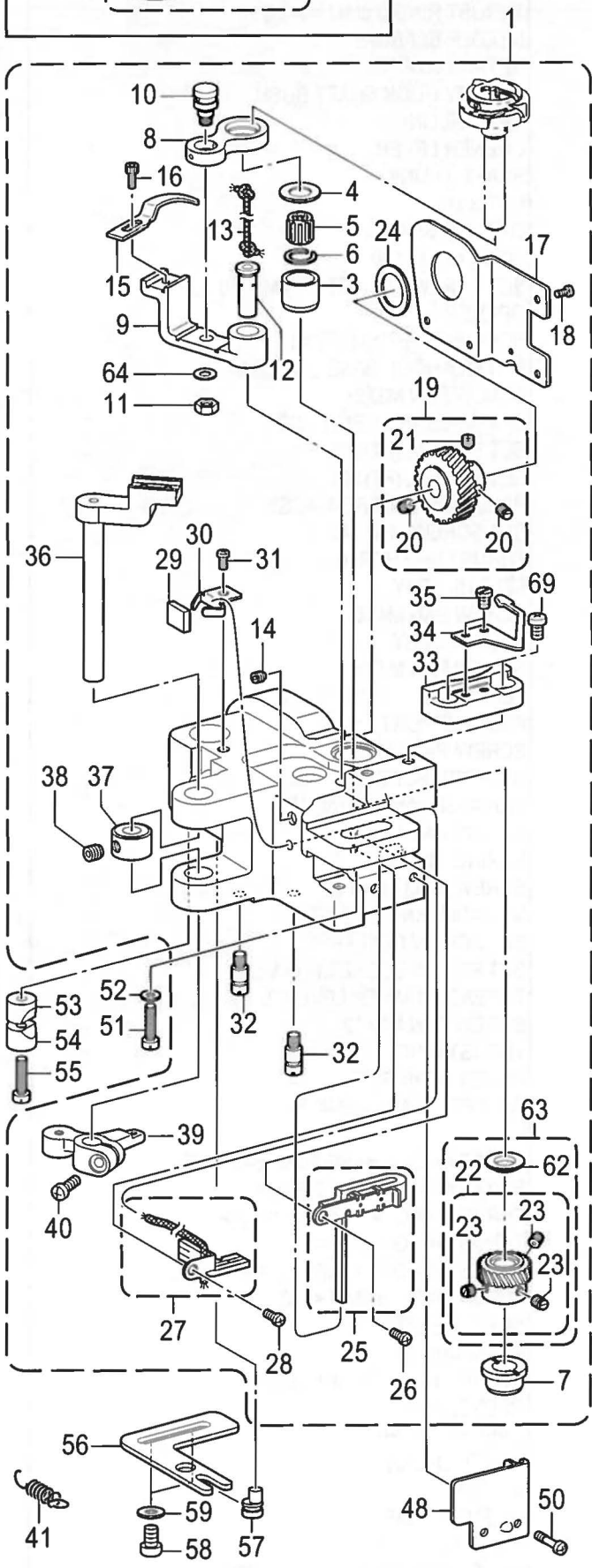

J2 . かま関係 (T-8422B) / Rotary hook mechanism (T-8422B)

REF.NO	CODE	Q'TY	品名	NAME OF PARTS	RM
15	S38212001	1	オープナー	OPENER	
16	154965001	1	アナボルト3.57X8	BOLT, SOCKET SM3.57X8	
43	SA2563301	1	カマドダイカバー-R	ROTARY HOOK BASE COVER, R	
18	062300612	4	ナベコ3X6	SCREW PAN M3X6	
19	SA2572001	1	スパイラルギヤ ネジツキ	SPIRAL GEAR SCREW ASSY	
20	SA2574001	2	トメネジM6ホソメ	SET SCREW, (FT) M6	
21	SA2575001	1	トメネジM6ホソメ	SET SCREW, (FT) M6	
22	SA6301001	1	ピニオン ネジツキ	PINION GEAR SCREW ASSY	
23	SA2574001	3	トメネジM6ホソメ	SET SCREW, (FT) M6	
44	SA2579001	1	スラストザガネ	SPECER	
45	SA6425101	1	フェルトURクミ	FELT UR ASSY	
26	062400616	1	ナベコ4X6	SCREW PAN M4X6	
46	SA4045001	1	フェルトDRクミ	FELT DR ASSY	
28	062400616	1	ナベコ4X6	SCREW PAN M4X6	
29	SA4012001	1	フェルト	FELT	
30	SA3894001	1	フェルトオサエ	FELT SUPPORT	
31	062400616	1	ナベコ4X6	SCREW PAN M4X6	
32	SA2717001	2	ストツパネジ	STOPPER SCREW	
33	SA2676001	1	イドウハウケ	MOVABLE KNIFE BRACKET	
69	062400812	2	ナベコ4X8	SCREW PAN M4X8	
34	S07525100	1	シタイトホジバネ	SPRING PLATE	
35	141544001	2	シメネジ3.18	SCREW, SM3.18-40X3	
36	SA3912001	1	イドウハレバー	MOVABLE KNIFE LEVER	
37	SA2675001	1	セットカラー	SET SCREW COLLAR	
38	S23651001	1	アナヒラ6X6ホソメ	SET SCREW SOCKET (FT) M6X6	
47	SA2670101	1	イトキリレバー-R	THREAD TRIMMER LEVER R	
40	062501212	1	ナベコ5X12	SCREW PAN M5X12	
62	SA6294101	1	スラストリング	THRUST RING	
63	SA6307101	1	ピニオンセット	PINION GEAR SET	
64	025710132	1	ヒラザガネシヨウ4.76	WASHER PLAIN S SM4.76	
			<-□□5用>	<For -□□5>	
41	SA2826001	1	イトキリレバーバネ	SPRING, EXTENSION	
			<-□□3用>	<For -□□3>	
41	SA4458001	1	イトキリレバーバネB	SPRING, EXTENSION, B	
48	SA6462001	1	カマドダイカバー-FL	ROTARY HOOK BASE COVER FL	
49	SA6463001	1	カマドダイカバー-FR	ROTARY HOOK BASE COVER FR	
50	SA6417001	4	シメネジM4X12	SCREW M4X12	
51	SA2556001	2	シメネジM6X25	SCREW, M6X25	
52	115947101	2	ザガネ	WASHER PLAIN 6.35	
53	SA2722001	2	ピンチスリーブA	PINCH SLEEVE A	
54	SA2565001	2	ピンチスリーブB	PINCH SLEEVE B	
55	SA2556001	2	シメネジM6X25	SCREW, M6X25	
56	SA2567001	2	ハリスキチヨウセツイタ	NEEDLE UPPER POSITIONING PLATE	
57	SA2568001	2	ハリスキチヨウセツジク	NEEDLE UPPER POSITIONING SHAFT	
58	062061016	4	ナベコ6X10	SCREW PAN M6X10	
59	025060136	4	ヒラザガネシヨウ6	WASHER PLAIN S 6	
60	S01928151	2	ボビン	BOBBIN	
61	148602001	2	クウテンボウシバネ	ANTI-SPIN SPRING	
			<オプション部品> ドライ仕様用	<Option parts> For dry type	
65	SA2827001	2	オープナーリンククミ	OPENER LINK ASSY	
66	SA2558001	2	オープナーリンク	OPENER LINK	
67	S58900000	2	セイミツネジM2	SCREW M2	
68	062400416	2	ナベコ4X4	SCREW, PAN M4X4	

< キャップ付 / With cap >  
(オプション部品 / Option parts)

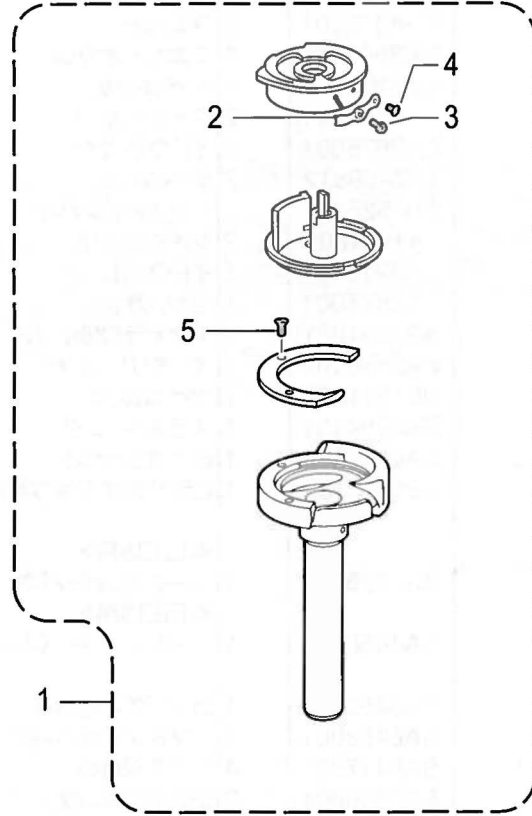
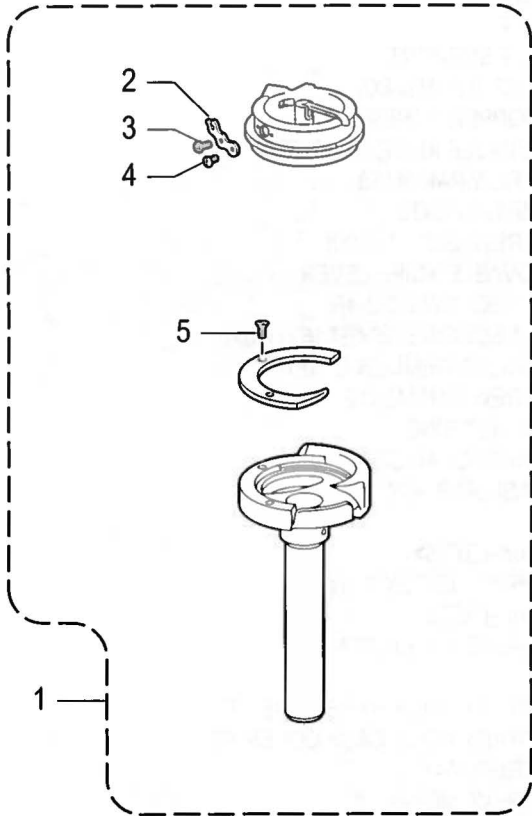

J3 . かま関係 / Rotary hook mechanism

REF.NO	CODE	Q'TY	品名	NAME OF PARTS	RM
1	* P.60-61	1	カマハコクミ	ROTARY HOOK ASSY	
2	* P.60-61	1	チヨウシバネ	TENSION SPRING	
3	* P.60-61	1	チヨウシネジ	TENSION ADJUSTING SCREW	
4	151030001	1	チヨウシバネトメネジ	SET SCREW	
5	151027001	2	ウチカマオサエトメネジ	SET SCREW	

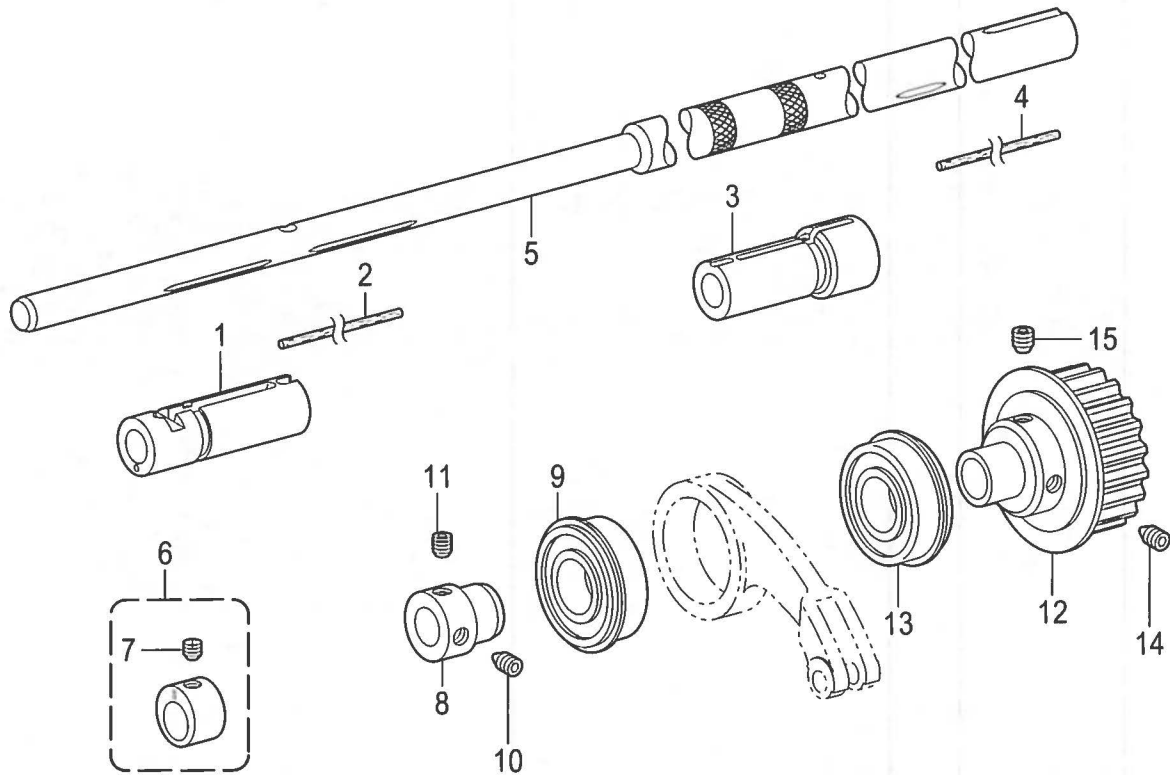



K . 下軸関係 / Lower shaft mechanism

REF.NO	CODE	Q'TY	品名	NAME OF PARTS	RM
1	SA3890001	1	カマドダイメタルL	ROTARY HOOK BASE BUSH, L	
2	SA4585001	1	フェルト	FELT	
3	SA3891001	1	カマドダイメタルR	ROTARY HOOK BASE BUSH, R	
4	SA4585001	1	フェルト	FELT	
5	SA2571001	1	シタジク	LOWER SHAFT	
6	SA2759101	1	< T-8421B用 > ジヨウゲヘンシンリンSTクミ	<For T-8421B > F-LIFTING ECCENTRIC WHEEL ASSY	
6	SA2580101	1	< T-8422B用 > ジヨウゲヘンシンリンTRクミ	<For T-8422B > F-LIFTING ECCENTRIC WHEEL ASSY	
7	SA2575001	1	トメネジM6ホソメ	SET SCREW (FT) M6	
8	SA2584001	1	タマジクウケブツシュ	BALL BEARING BUSH	
9	S38707001	1	タマジクウケ6004ZZNR	BALL BEARING, 6004ZZNR	
10	SA2585001	1	アナトガリ6X10ホソメ	SET SCREW, SOCKET (FT) M6	
11	S23651001	1	アナヒラ6X6ホソメ	SET SCREW SOCKET (FT) M6X6	
12	SA2587101	1	タイミングプーリDクミ	TIMING PULLEY ASSY, D	
13	158115001	1	タマジクウケ6204ZZNR	BALL BEARING, 6204ZZNR	
14	SA2585001	1	アナトガリ6X10ホソメ	SET SCREW, SOCKET (FT) M6	
15	SA4213001	1	アナトメネジ6X10ホソメ	SET SCREW SOCKET (CP) M6X10	

T-8422B-305



## L. 給油潤滑関係 / Lubrication

REF.NO	CODE	Q'TY	品名	NAME OF PARTS	RM
			<-□0□用>	<For -□0□>	
1	SA4205101	1	オイルタンククミ	OIL TANK ASSY	
2	SA3040001	2	オイルクチ	OIL FEEDING PIPE	
3	SA5026101	1	ポンプフタネジ	SCREW M8X7	
4	SA3946001	1	キユウユタ-ミナル	OIL TERMINAL	
5	SA2956001	1	ビニルチューブ	OIL TUBE, L=135	
6	SA2957001	2	フェルト	FELT	
7	SA3055101	2	チューブストツパー	TUBE CLIP	
8	SA6178001	2	クリップ	CLIP	
9	062500816	1	ナベコ5X8	SCREW PAN M5X8	
10	SA2929001	2	ゴムセン12.5	RUBBER CAP, 12.5	
11	S38266000	1	カマジクフェルト	ROTARY HOOK SHAFT FELT	
12	SA4215101	1	フェルトクミ	FELT ASSY	
13	SA4033101	1	フェルトオサエ	FELT SUPPORT	
14	228475000	1	ケツソクバンド1.9X80	FASTENING BAND 1.9X80	
			<-□3□用>	<For -□3□>	
15	SA5304001	1	オイルタンククミ	OIL TANK ASSY	
16	SA5026101	2	ポンプフタネジ	SCREW M8X7	
17	SA3040001	1	オイルクチ	OIL FEEDING PIPE	
64	SA3055101	1	チューブストツパー	TUBE CLIP	
18	SA2929001	2	ゴムセン12.5	RUBBER CAP, 12.5	
19	104450101	1	ゴムセン8	RUBBER CAP, 8	
20	081038070	1	OリングP38	O RING P38	
21	SA2723001	1	ビニルチューブ	OIL TUBE, L=210	
22	SA2724001	1	クミヒモ	WICK, L=400	
23	0A5501006	2	+ナベザクミ5X10DB	SCREW PAN (S/P WASHER) M5X10	
24	SA7540001	1	キユウユブロツクセット	OIL BLOCK SET	
25	SA6475001	2	オイルチヨウセツネジ	OIL ADJUSTING SCREW	
26	081004070	2	OリングP4	O RING P4	
27	SA6468001	2	ゴムパツキン	RUBBER PACKING	
28	SA6423001	2	カマジクフェルト	ROTARY HOOK SHAFT FELT	
29	SA6415001	2	クミヒモ	WICK L=80	
30	142274101	2	ゴムセン4.2	RUBBER CAP, 4.2	
31	SA7548001	1	サブタンクセット	SUB-TANK SET	
32	SA3040001	1	オイルクチ	OIL FEEDING PIPE	
33	SA3060001	1	バルブパツキン	VALVE PACKING	
34	104450101	1	ゴムセン8	RUBBER CAP, 8	
35	0A4400806	2	+ナベザクミ4X8DA	SCREW PAN (S/P WASHER) M4X8	
36	SA3045201	1	サブタンクトリツケイタA	SUB-TANK SETTING PLATE A	
37	SA3046001	1	サブタンクトリツケイタB	SUB-TANK SETTING PLATE, B	
38	062060816	2	ナベコ6X8	SCREW PAN M6X8	
39	SA3044001	1	ビニルチューブ	OIL TUBE, L=242	
40	SA3055101	2	チューブストツパー	TUBE CLIP	
41	SA6472001	1	チューブササエ	TUBE SUPPORT	
42	SA3923101	2	カマダイDパツキン	ROTARY HOOK BASE D PACKING	
43	062401616	4	ナベコ4X16	SCREW PAN M4X16	
44	SA2604001	1	キリカエキフェルト	FEED REGULATOR FELT	
45	SA2605001	1	フェルトオサエイタ	FELT SUPPORT	
46	062500616	1	ナベコ5X6	SCREW PAN M5X6	
47	109405001	1	クミヒモ4X4	WICK 4X4 (L=100)	
48	108801001	1	クミヒモ4X4	WICK, 4X4 L=350	
49	SA2606101	1	オイルカバー	OIL COVER	
50	104450101	1	ゴムセン8	RUBBER CAP, 8	
51	SA3048101	1	チューブオサエA	TUBE SUPPORT, A	
52	SA3049001	1	チューブオサエB	TUBE SUPPORT, B	
53	062400616	1	ナベコ4X6	SCREW PAN M4X6	
54	SA6473001	1	チューブガイド	TUBE GUIDE	
55	140890009	1	オイルカツブ	OIL CAP	
56	112753001	2	フェルト	FELT	

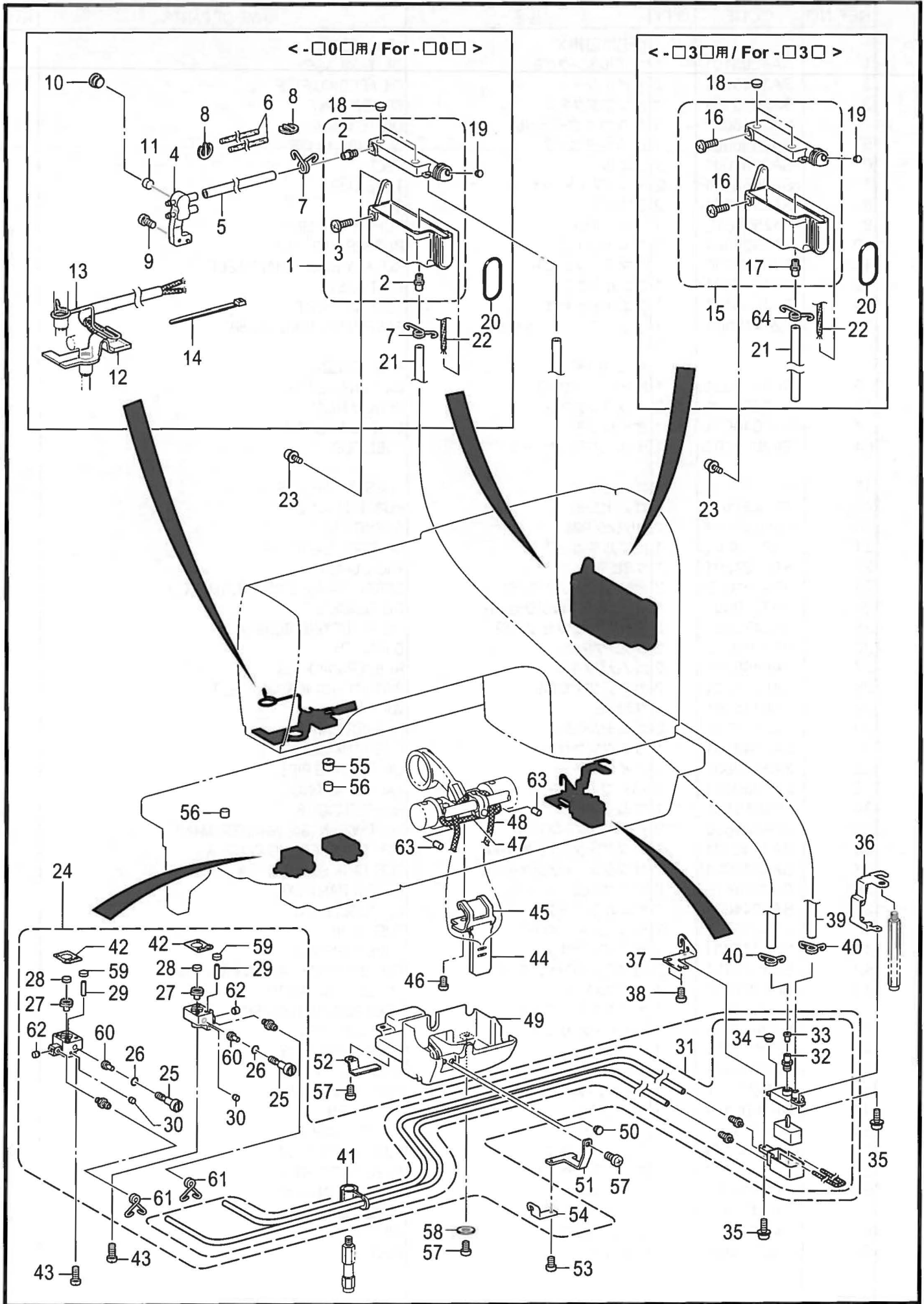

## L. 給油潤滑関係 / Lubrication

REF.NO	CODE	Q'TY	品名	NAME OF PARTS	RM
57	062061016	3	ナベコ6X10	SCREW PAN M6X10	
58	025060236	1	ヒラザガネチュウ6	WASHER PLAIN M 6	
59	SA6423001	2	カマジクフェルト	ROTARY HOOK SHAFT FELT	
60	SA6416001	2	ゴムオサエ	RUBBER PRESSER	
61	SA6414001	2	チューブストツパー	TUBE CLIP	
62	140327001	2	ゴムセン6.3	RUBBER CAP, 6.3	
63	148743001	2	フェルト	FELT	

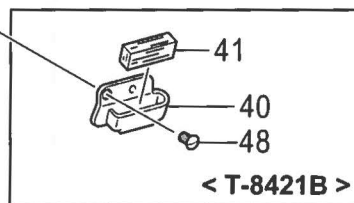
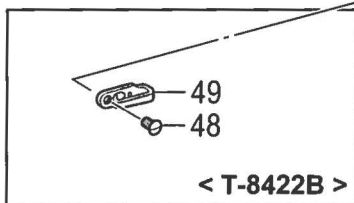
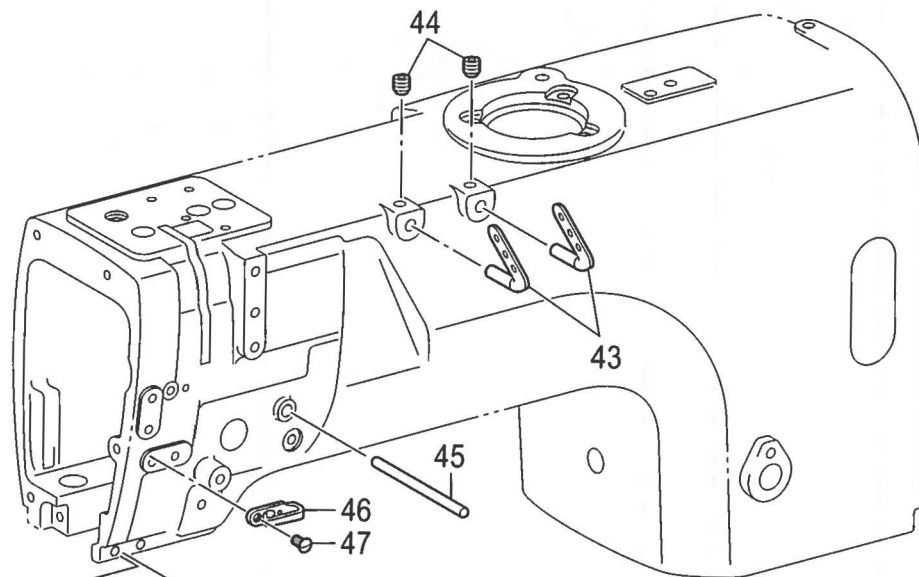
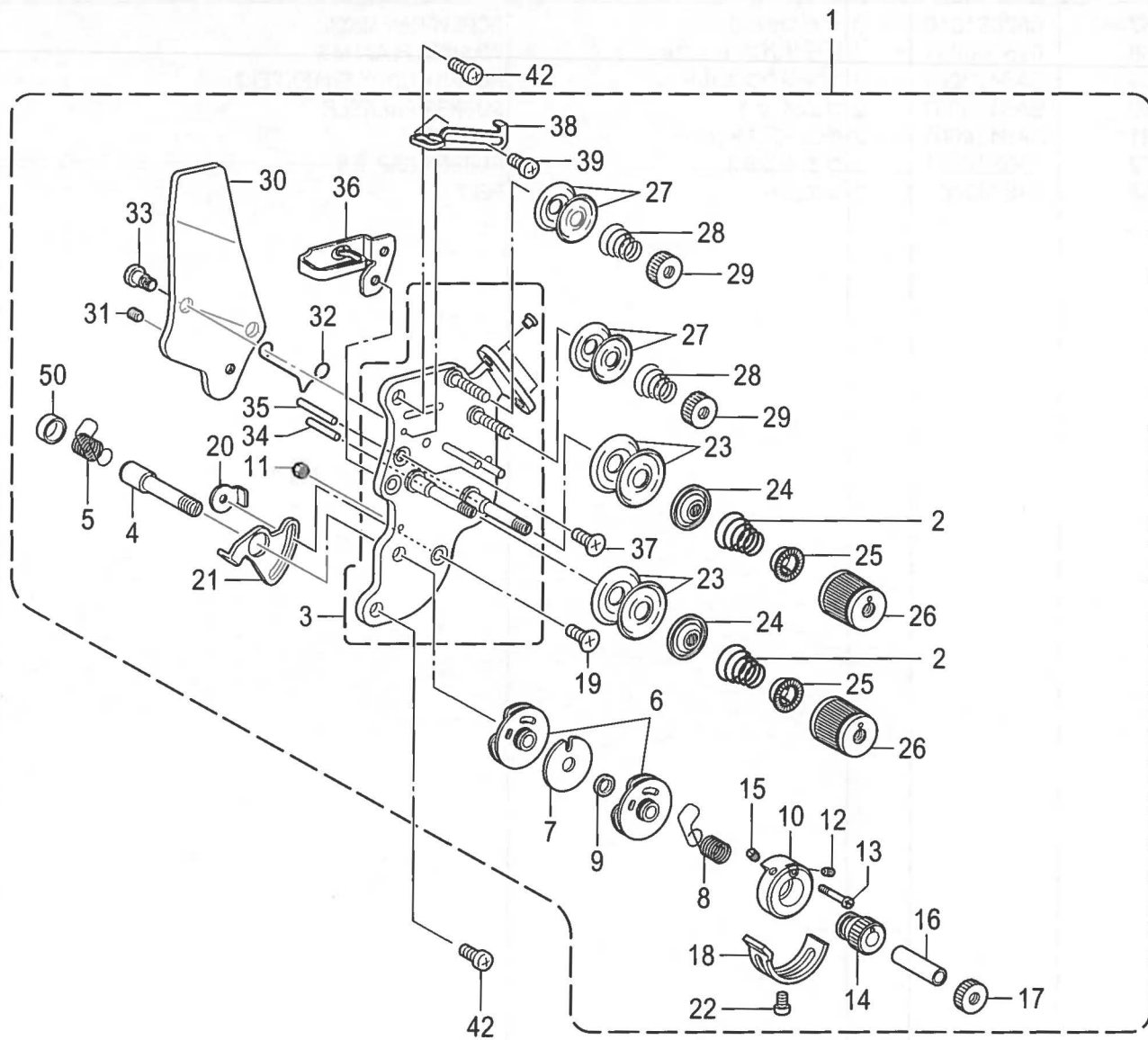

M . 糸通し関係 / Threading mechanism

REF.NO	CODE	QTY	品名	NAME OF PARTS	RM
			<-□□3用>	<For -□□3>	
1	SA3417301	1	ウワイトチヨウシクミ-3	UPPER THREAD TENSION ASSY -3	
2	SA3415001	2	イトチヨウシバネL	TENSION SPRING, L	
			<-□□5用>	<For -□□5>	
1	SA2607301	1	ウワイトチヨウシクミ-5	UPPER THREAD TENSION ASSY -5	
2	SA3416101	2	イトチヨウシバネLL	TENSION SPRING LL	
			<-□□F用>	<For -□□F>	
1	SA2818301	1	ウワイトチヨウシクミ-1	UPPER THREAD TENSION ASSY -1	
2	SA3414101	2	イトチヨウシバネM	TENSION SPRING M	
3	SA4212001	1	イトチヨウシダイクミ	TENSION PLATE ASSY	
4	SA2613001	1	チヨウシジク	TENSION STUD	
5	SA2614201	1	イトトリバネL	THREAD TAKE-UP SPRING L	
6	SA2615001	2	イトトリバネアンナイクミ	GUIDE ASSY, T/TAKE-UP SPRING	
7	SA2619001	1	スペーサー	SPACER	
8	SA2623201	1	イトトリバネR	THREAD TAKE-UP SPRING R	
9	SA2620001	1	カラ-	COLLAR	
10	SA2621001	1	ストツパウケ	STOPPER SUPPORT	
11	021300106	1	1シユナツツ3	NUT 1 M3	
12	SA2626001	1	トメネジ3.5	SET SCREW, (CP) M3.5	
13	SA2624001	1	バネアンナイトメネジ	SPRING GUIDE SET SCREW	
14	SA2625001	1	チヨウセツツマミ	ADJUSTING THUMB	
15	SA2626001	1	トメネジ3.5	SET SCREW, (CP) M3.5	
16	SA2627001	1	カラ-	COLLAR	
17	SA2628001	1	イトチヨウシナツト	TENSION NUT	
18	SA2629001	1	イトトリバネストツパ	STOPPER	
19	061350616	1	サラコ35X6	SCREW FLAT M3.5X6	
20	SA2824001	1	マワリドメナツトM3.5	NUT, WHIRL-STOP M3.5	
21	SA2630001	1	イトトリバネストツパ	STOPPER	
22	062350512	1	ナベコ35X5	SCREW PAN M3.5X5	
23	145446001	4	イトチヨウシサラ	DISC, TENSION	
24	159805001	2	イトチヨウシサラオサエ	TENSION DISC PRESSER	
25	S20681000	2	チヨウシバネウエザガネ	WASHER	
26	S20682105	2	イトチヨウシナツト	TENSION NUT	
27	144504001	4	イトアンナイサラ	THREAD GUIDE DISC	
28	154560101	2	プレテンションバネA	PRE-TENSION SPRING A	
29	155510001	2	イトチヨウシナツト	TENSION NUT	
30	SA2632001	1	イトユルメイタ	TENSION RELEASE PLATE	
31	012500536	1	アナヒラ5X5	SET SCREW SOCKET (FT) M5X5	
32	S38274001	1	イトユルメバネ	T-RELEASE SPRING	
33	SA2633001	2	ダンネジ3.5	SHOULDER SCREW, M3.5	
34	SA4506001	1	イトユルメピンL	TENSION RELEASE PIN, L	
35	SA4507001	1	イトユルメピンR	TENSION RELEASE PIN, R	
36	SA2634001	1	ア-ムイトアンナイU	THREAD GUIDE, U: ARM	
37	061350616	2	サラコ35X6	SCREW FLAT M3.5X6	
38	SA2635001	1	イトリヨウチヨウセイ	THREAD QUANTITY ADJUST	
39	062300616	1	ナベコ3X6	SCREW PAN M3X6	
42	062500816	2	ナベコ5X8	SCREW PAN M5X8	
43	SA2636001	2	ミツメイトカケ	THREAD RETAINER	
44	012060636	2	アナヒラ6X6	SET SCREW SOCKET (FT) M6X6	
45	SA2637001	1	イトユルメジク	BAR, TENSION RELEASE	
46	SA2638001	1	ア-ムイトアンナイM	THREAD GUIDE, M: ARM	
47	SA2640001	1	サラネジ5X8	SCREW FLAT M5X8	
50	SA6378001	1	キャツブ	CAP	
			<T-8421B用>	<For T-8421B>	
40	SA2639001	1	ア-ムイトアンナイD	THREAD GUIDE, D: ARM	
41	114941001	1	ア-ムイトアンナイフェルト	FELT	
48	SA2640001	1	サラネジ5X8	SCREW, FLAT M5X8	
			<T-8422B用>	<For T-8422B>	
48	SA2640001	1	サラネジ5X8	SCREW FLAT M5X8	
49	SA2638001	1	ア-ムイトアンナイM	THREAD GUIDE, M: ARM	

T-8421B/8422B-401

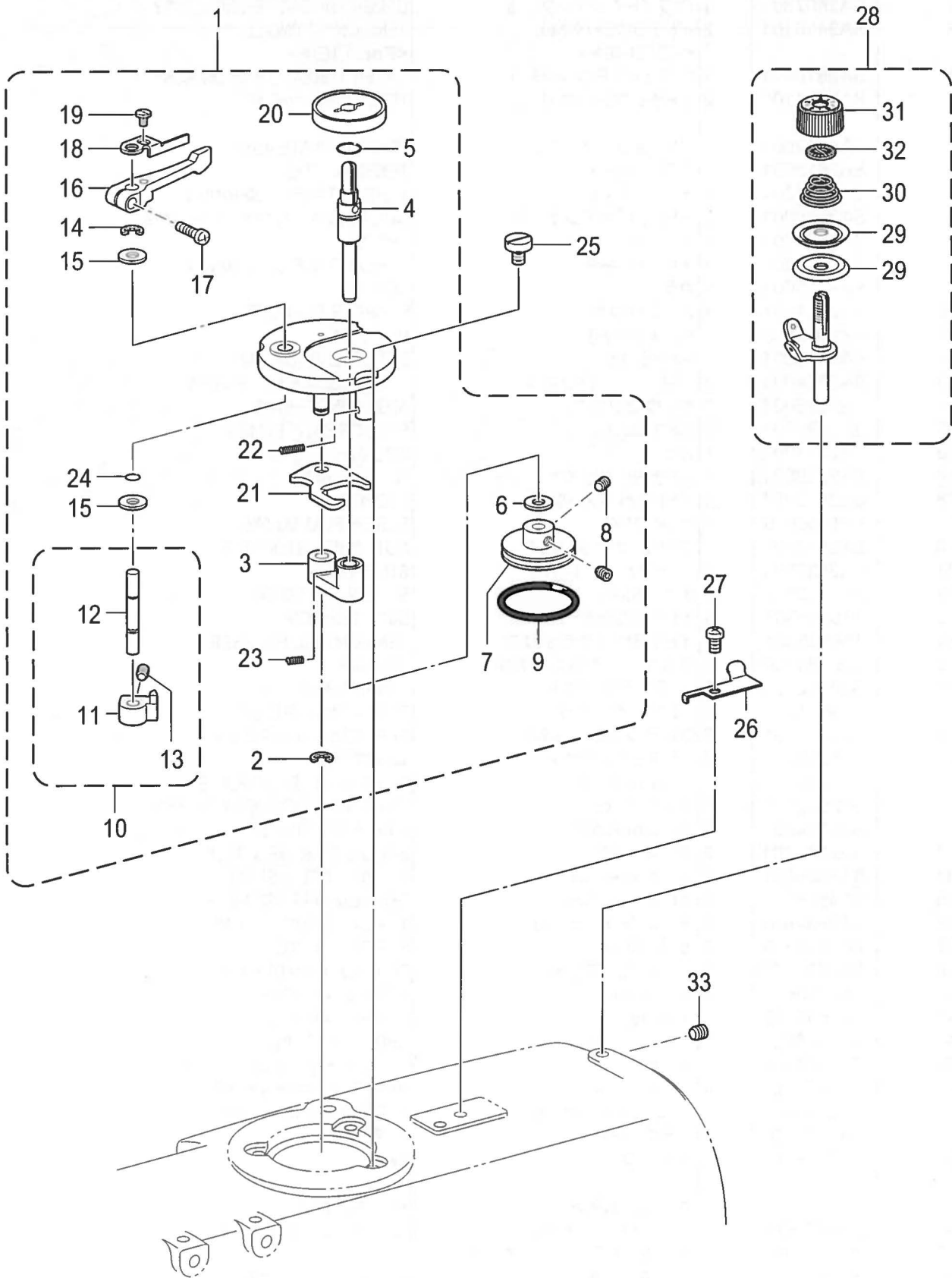



N . 糸巻関係 / Bobbin winder mechanism

REF.NO	CODE	Q'TY	品名	NAME OF PARTS	RM
1	SA1971101	1	イトマキユニット	BOBBIN WINDER UNIT	
2	048040342	1	トメワE4	RETAINING RING, E4	
3	SA1975001	1	イトマキジクウケクミ	B-WINDER SHAFT SUPPORT ASSY	
4	SA1978001	1	イトマキジク	BOBBIN WINDER SHAFT	
5	081009070	1	OリングP9	O RING, P9	
6	025060136	1	ヒラザガネシヨウ6	WASHER, PLAIN S 6	
7	SA1980001	1	イトマキクルマ	BOBBIN WINDER WHEEL	
8	012500536	2	アナヒラ5X5	SET SCREW, SOCKET (FT) M5X5	
9	S25789000	1	ゴムワ29	RUBBER RING, 29	
10	SA1981101	1	ボビンオサエカムクミ	BOBBIN PRESSER CAM ASSY	
11	SA1982101	1	ボビンオサエカム	BOBBIN PRESSER CAM	
12	SA1983001	1	イトマキウデジク	BOBBIN WINDER ARM SHAFT	
13	012500536	1	アナヒラ5X5	SET SCREW, SOCKET (FT) M5X5	
14	048040342	1	トメワE4	RETAINING RING, E4	
15	025060136	2	ヒラザガネシヨウ6	WASHER, PLAIN S 6	
16	SA1984001	1	ボビンオサエウデ	BOBBIN PRESSER ARM	
17	062401216	1	ナベコ4X12	SCREW, PAN M4X12	
18	SA1985001	1	ボビンオサエ	BOBBIN PRESSER	
19	S23418002	1	シメネジ4X5	SCREW, M4X5	
20	SA1988001	1	ボビンウケ	BOBBIN SUPPORT	
21	SA1989001	1	イトマキレバー	BOBBIN WINDER LEVER	
22	SA1990101	1	モドシバネ	SPRING	
23	SA1991001	1	イトマキダイバネ	BOBBIN WINDER BASE SPRING	
24	SA2190001	1	OリングSS5	O RING, SS5	
25	SA1992101	3	イトマキコテイネジ	BOBBIN WINDER FIXED SCREW	
26	SA1360101	1	メス	KNIFE	
27	062500616	1	ナベコ5X6	SCREW, PAN M5X6	
28	SA1994101	1	イトマキチヨウシクミ	BOBBIN WINDER TENSION ASSY	
29	145446002	2	イトチヨウシサラ	DISC, TENSION	
30	100401022	1	イトチヨウシバネ	TENSION SPRING	
31	S31032001	1	イトチヨウシナツト	TENSION NUT	
32	S12441001	1	チヨウシバネウエザガネ	WASHER	
33	012500536	1	アナヒラ5X5	SET SCREW, SOCKET (FT) M5X5	

< T-8422B >

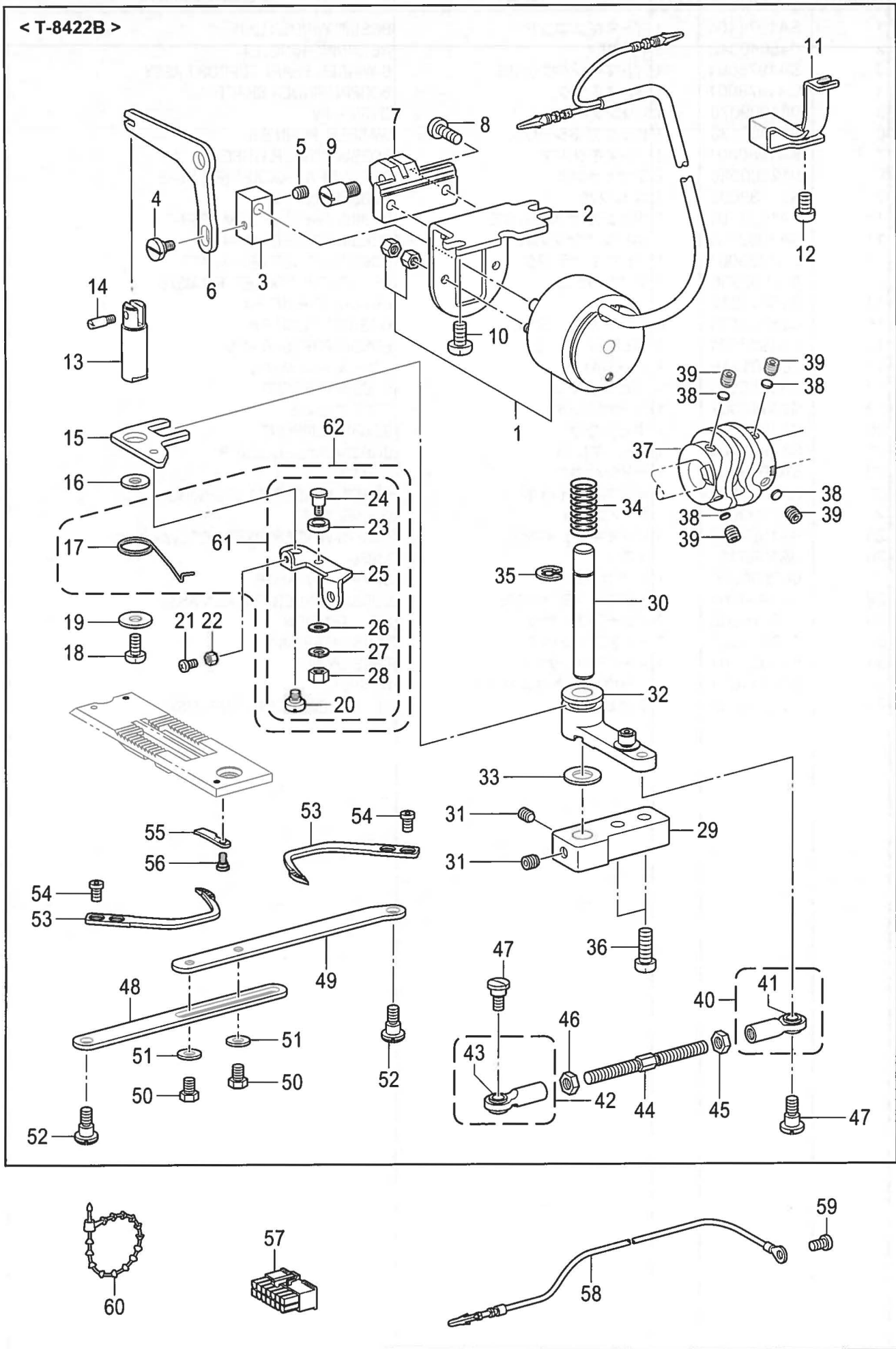

P . 糸切り関係 / Thread trimmer mechanism

REF.NO	CODE	Q'TY	品名	NAME OF PARTS	RM
			< T-8422B用 >	< For T-8422B >	
1	SA2642001	1	イトキリソレノイド	THREAD TRIMMER SOLENOID	
2	SA2643001	1	ソレノイドシジイタ	SOLENOID BRACKET	
3	SA2644001	1	ソレノイドツギテ	SOLENOID JOINT	
4	SA2645001	1	ダンネジM5	SHOULDER SCREW, M5	
5	012500536	1	アナヒラ5X5	SET SCREW SOCKET (FT) M5X5	
6	SA2646001	1	ソレノイドレバー	SOLENOID LEVER	
7	SA2728001	1	ソレノイドレバーウケ	SOLENOID LEVER BRACKET	
8	062501016	2	ナベコ5X10	SCREW PAN M5X10	
9	SA2647001	1	ソレノイドレバージク	SOLENOID LEVER SHAFT	
10	062061012	2	ナベコ6X10	SCREW PAN M6X10	
11	SA2648001	1	コードオサエ	CORD HOLDER	
12	062060816	1	ナベコ6X8	SCREW PAN M6X8	
13	SA2651001	1	イトキリジク	DRIVING ROD	
14	148546001	1	プランジヤピン	PLUNGER PIN	
15	SA2652101	1	イトキリジクイタ	DRIVING ROD PLATE, TR	
16	SA2860001	1	ザガネ	WASHER	
17	SA6395001	1	イトユルメレバーバネ	SPRING	
18	062501016	1	ナベコ5X10	SCREW PAN M5X10	
19	116662003	1	ザガネ	WASHER	
20	SA2655001	1	ダンネジM4	SHOULDER SCREW, M4	
21	062351216	1	ナベコ35X12	SCREW PAN M3.5X12	
22	021350106	1	1シュナツト35	NUT 1 M3.5	
23	SA6392001	1	イトユルメコロ	ROLLER	
24	SA6393001	1	イトユルメコロジク	ROLLER SHAFT	
25	SA6394001	1	イトユルメレバー	TENSION RELEASE LEVER	
26	113431002	1	ザガネ	WASHER, PLAIN	
27	028050246	1	バネザガネ2-5	WASHER SPRING 2-5	
28	021500106	1	1シュナツト5	NUT 1 M5	
29	SA2657001	1	シュレバージクササエ	MAIN LEVER SUPPORT SHAFT	
30	SA2658001	1	シュレバージク	MAIN LEVER SHAFT	
31	012060636	2	アナヒラ6X6	SET SCREW SOCKET (FT) M6X6	
32	SA2659001	1	シュレバークミ	MAIN LEVER ASSY	
33	148559100	1	ゴム	RUBBER	
34	S07509001	1	シュレバーバネ	MAIN LEVER SPRING	
35	048070342	1	トメフE7	RETAINING RING E7	
36	062061616	2	ナベコ6X16	SCREW PAN M6X16	
37	SA2661001	1	イトキリカム	THREAD TRIMMER CAM	
38	SA2378001	4	カンザ4.8	SPACER, 4.8	
39	S25236001	4	アナヒラ6X10ホソメ	SET SCREW SOCKET (FT) M6X10	
40	SA2663001	1	タマツギテRクミ	ROUND JOINT ASSY R	
41	141331002	1	キュウメンブシユ	BUSH	
42	SA2665001	1	タマツギテLクミ	ROUND JOINT ASSY L	
43	141331002	1	キュウメンブシユ	BUSH	
44	SA2667001	1	ナガサチヨウセツレンカン	L-ADJUSTING CONNECTING ROD	
45	021060306	1	3シュナツト6	NUT 3 M6	
46	SA2668001	1	ナツト6ヒダリ	NUT M6 LEFT	
47	SA2669001	2	タマツギテダンネジ	SHOULDER SCREW, SM5.95-28	
48	SA2672001	1	イトキリレンカンR	T-TRIMMER CONNECTING ROD, R	
49	SA2673001	1	イトキリレンカンL	T-TRIMMER CONNECTING ROD, L	
50	017500812	2	ボルト5X8	BOLT M5X8	
51	025050236	2	ヒラザガネチユウ5	WASHER PLAIN M 5	
52	SA2645001	2	ダンネジM5	SHOULDER SCREW, M5	
53	S07526301	2	イドウハ	MOVABLE KNIFE	
54	148536001	4	シメネジ4.37	SCREW, W/SOCKET SM4.37-40X4.2	
55	S07527001	2	コテイハ	FIXED KNIFE	
56	148539101	2	ダンネジ2.38	SHOULDER SCREW, SM2.38	
61	SA8364001	1	イトユルメレバークミ	TENSION RELEASE LEVER ASSY	
62	SA8365001	1	イトユルメレバーセット	TENSION RELEASE LEVER SET	

T-8421B/8422B-403

< T-8422B >

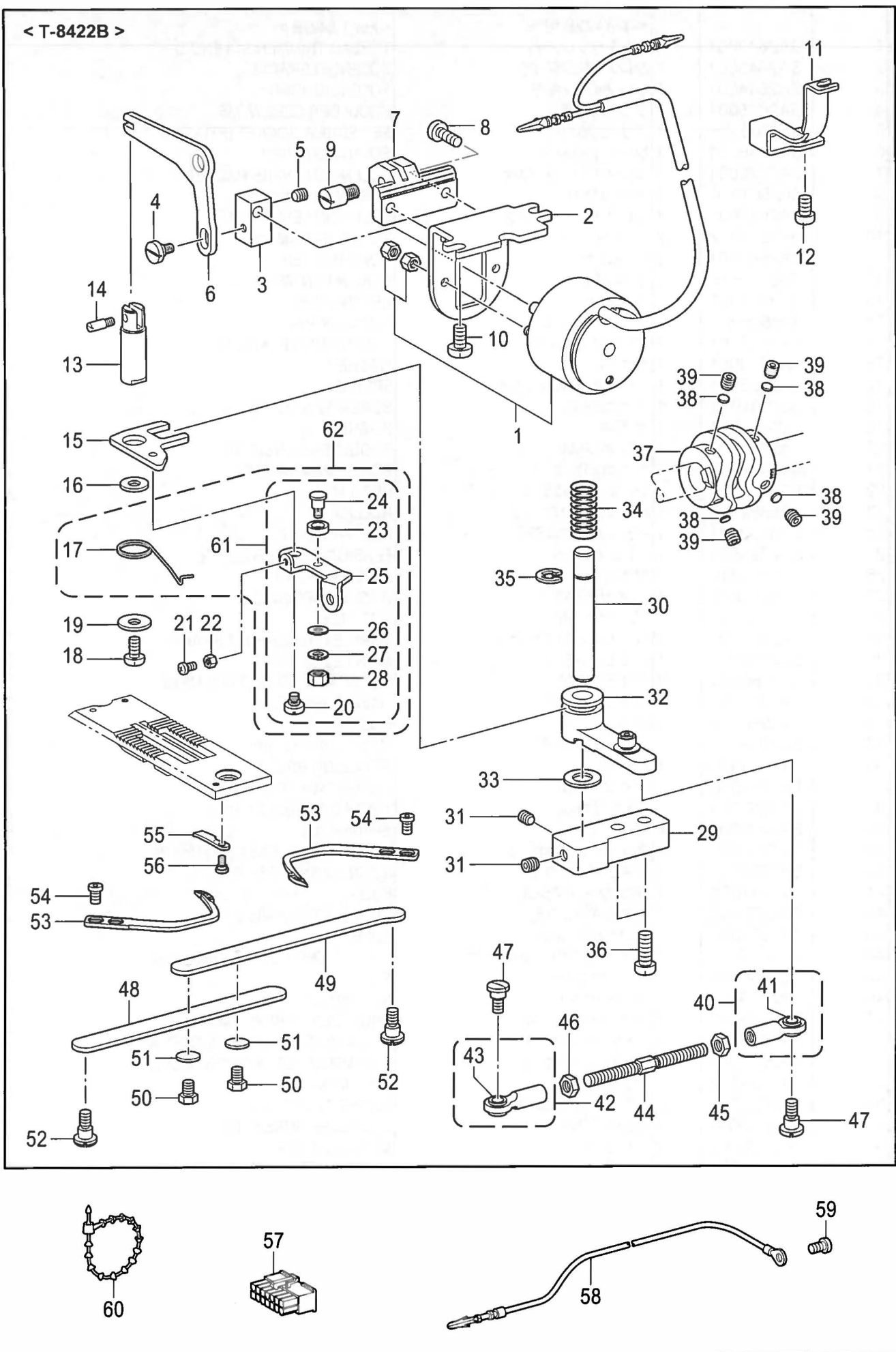

P . 糸切り関係 / Thread trimmer mechanism

REF.NO	CODE	Q'TY	品名	NAME OF PARTS	RM
			< T-8421B / 8422B用 >	< For T-8421B / 8422B >	
57	S38687000	1	コネクタ5557-14R	CONNECTOR, 5557-14R	
58	SA1998001	1	アースセンクミ	GROUND WIRE ASSY	
59	062500816	1	ナベコ5X8	SCREW PAN M5X8	
60	340400001	2	ユニタイバンド	BEAD BAND	

T-8421B/8422B-403

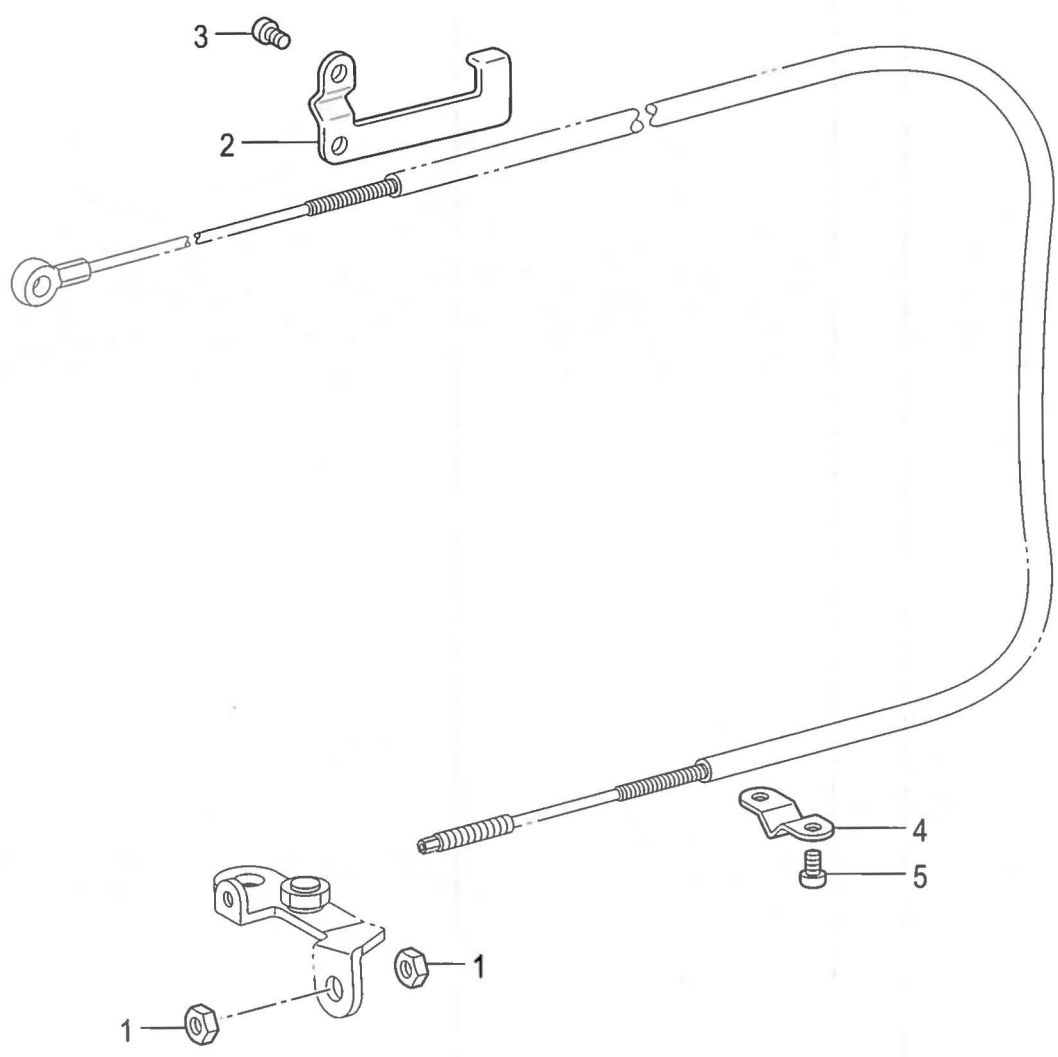

Q . 糸緩め関係 (T-8422B) / Tension release mechanism (T-8422B)

REF.NO	CODE	Q'TY	品名	NAME OF PARTS	RM
1	110161004	2	ナツト4.76	NUT, SM4.76	
2	SA2678001	1	イトユルメワイヤ-オサエ	TENSION RELEASE WIRE HOLDER	
3	062500816	2	ナベコ5X8	SCREW PAN M5X8	
4	SA2679001	1	イトユルメワイヤ-オサエ	TENSION RELEASE WIRE HOLDER	
5	062060816	2	ナベコ6X8	SCREW PAN M6X8	

T-8422B-404

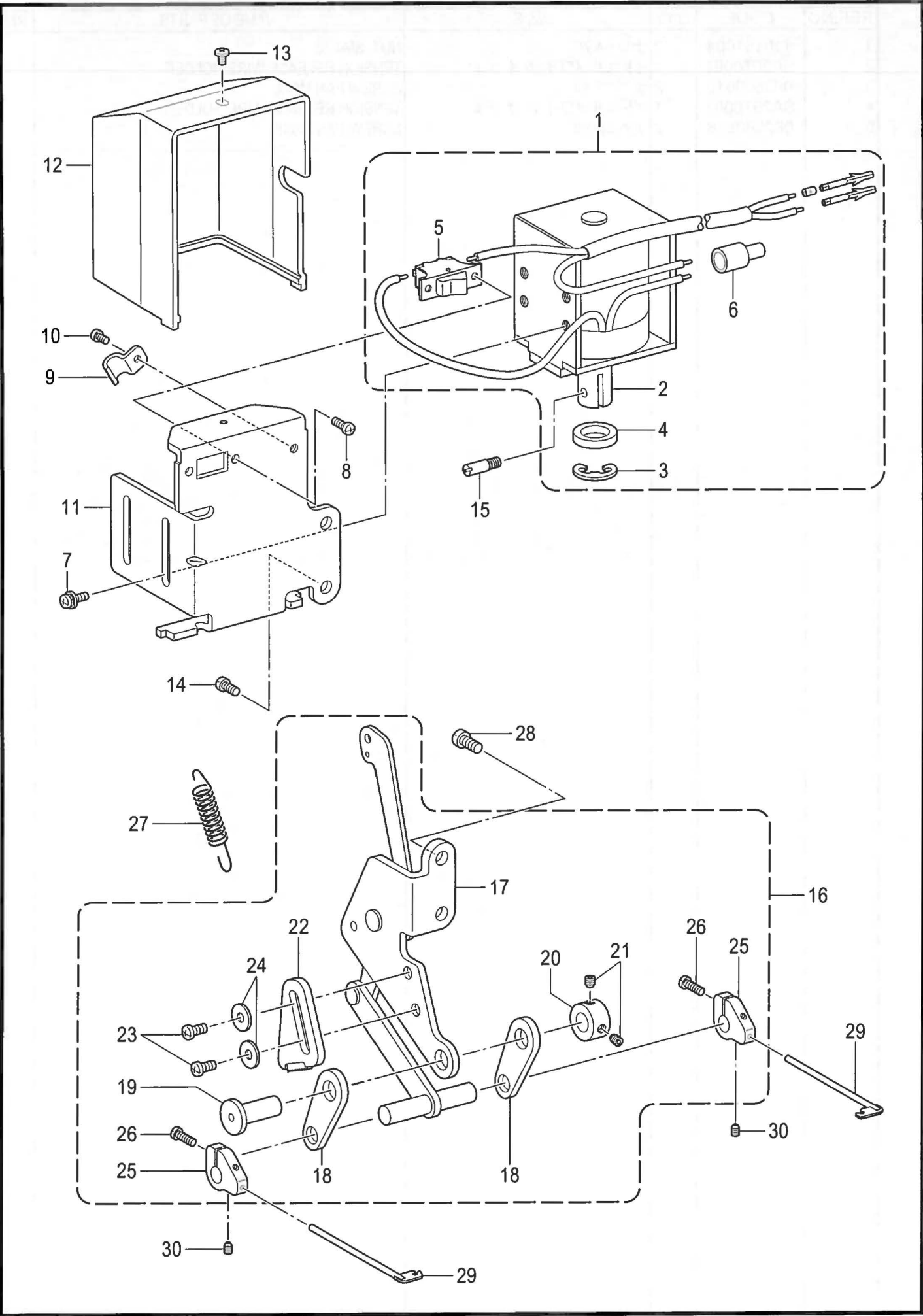



## R . 糸払い関係 (T-8422B) / Thread wiper mechanism (T-8422B)

REF.NO	CODE	Q'TY	品名	NAME OF PARTS	RM
1	SA2680001	1	イトハライソレノイドクミ	THREAD WIPER SOLENOID ASSY	
2	148511001	1	プランジャ	PLUNGER	
3	048090342	1	トメワE9	RETAINING RING E9	
4	S38426000	1	プランジャゴム	PLUNGER RUBBER	
5	S02664001	1	イトハライスイッチ	THREAD WIPER SWITCH	
6	S02665000	1	ヘイタンセツゾクシ	TERMINAL CONNECTOR	
7	S39048001	4	ナベザクミM4X10	SCREW, PAN (S/P W) M4X10	
8	062300616	2	ナベコ3X6	SCREW PAN M3X6	
9	140647101	1	コードオサエ	CORD HOLDER	
10	062400616	1	ナベコ4X6	SCREW PAN M4X6	
11	SA2732001	1	ソレノイドホジイタ	SOLENOID HOLDING PLATE	
12	SA2696001	1	ソレノイドカバー	SOLENOID COVER	
13	060400516	1	バインド4X5	SCREW BIND M4X5	
14	062501016	2	ナベコ5X10	SCREW PAN M5X10	
15	148546001	1	プランジャピン	PLUNGER PIN	
16	SA2682101	1	イトハライリンククミ	THREAD WIPER LINK ASSY	
17	SA2683001	1	ソレノイドリンク	SOLENOID LINK	
18	S07549101	2	イトハライリンクC	THREAD WIPER LINK, C	
19	S07550001	1	リンクジク	LINK STUD	
20	SA2504001	1	セットカラー	SET SCREW COLLAR	
21	012500536	2	アナヒラ5X5	SET SCREW SOCKET (FT) M5X5	
22	S38421001	1	ストツパ	STOPPER	
23	062500816	2	ナベコ5X8	SCREW PAN M5X8	
24	025050236	2	ヒラザガネチユウ5	WASHER PLAIN M 5	
25	S07552101	2	イトハライウケ	THREAD WIPER SUPPORT	
26	062661212	2	ナベコ318-40X12	SCREW PAN SM3.18-40X12	
27	SA2684001	1	イトハライバネ	THREAD WIPER SPRING	
28	062501016	2	ナベコ5X10	SCREW PAN M5X10	
29	S07553001	2	イトハライ	THREAD WIPER	
30	S07424001	2	トメネジ3.18	SET SCREW, W/SOCKET SM3.18X4	

S1. コントロールボックス、モータ関係 / Control box and motor mechanism

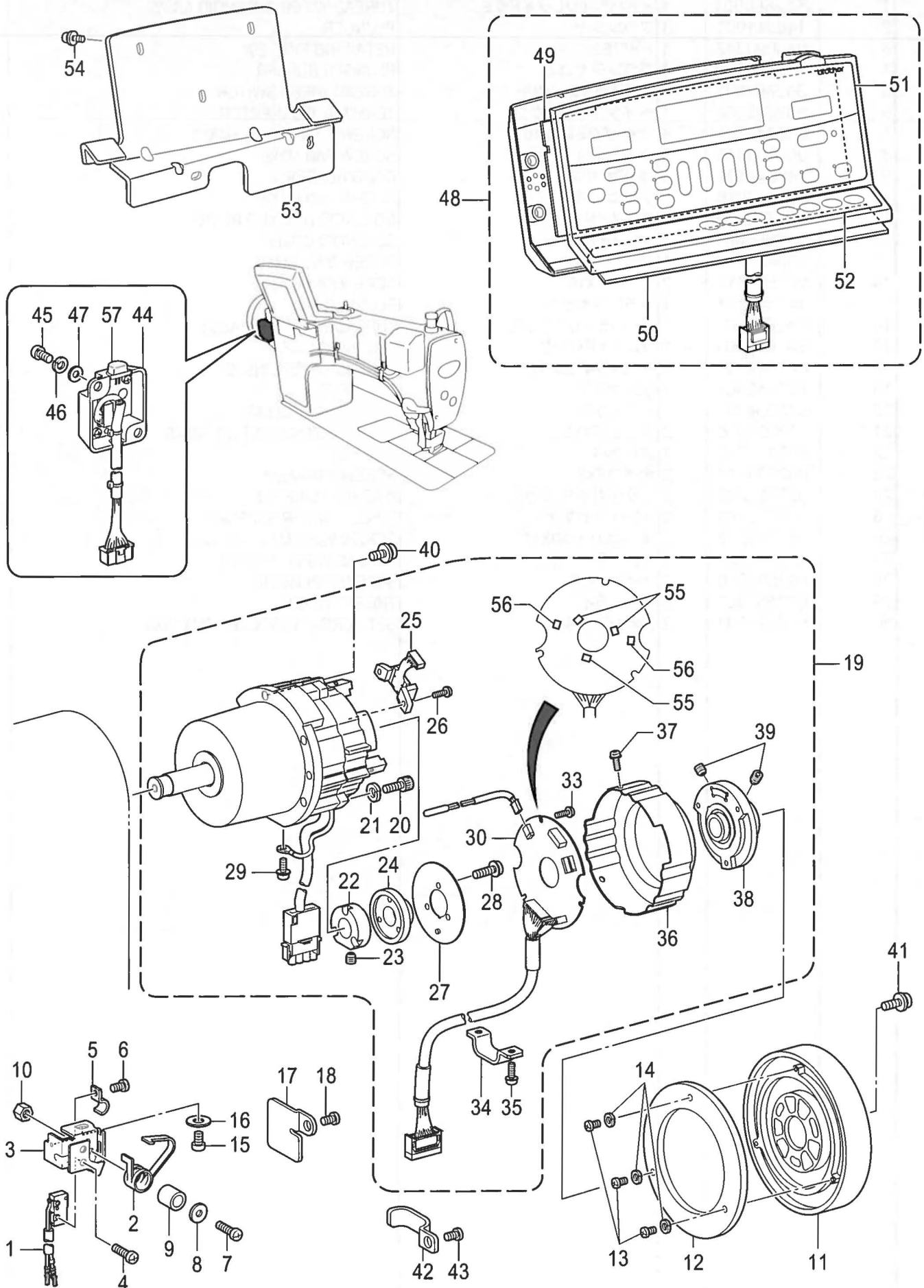

T-8421B/8422B-502

S1 . コントロールボックス、モータ関係 / Control box and motor mechanism

REF.NO	CODE	QTY	品名	NAME OF PARTS	RM
1	SA1385001	1	マイクロスイッチクミ	MICRO SWITCH ASSY	
2	S38744101	1	スイッチイタバネ	SWITCH PLATE SPRING	
3	SA2686001	1	スイッチダイ	SWITCH BASE	
4	062020806	2	ナベコ2X8	SCREW PAN M2X8	
5	140647101	1	コードオサエ	CORD HOLDER	
6	062400616	1	ナベコ4X6	SCREW PAN M4X6	
7	062401216	1	ナベコ4X12	SCREW PAN M4X12	
8	026040236	1	ヒラザガネミガキ4	WASHER PLAIN M 4	
9	154514001	1	スペーサー	SPACER	
10	021400106	1	1シユナツト4	NUT 1 M4	
11	SA4040001	1	プ-リCDD	PULLEY, CDD	
12	SA3175001	1	ガードプレート	GUARD PLATE	
13	062300616	3	ナベコ3X6	SCREW PAN M3X6	
14	028030246	3	バネザガネ2-3	WASHER SPRING 2-3	
15	062060812	1	ナベコ6X8	SCREW PAN M6X8	
16	025060136	1	ヒラザガネシヨウ6	WASHER PLAIN S 6	
17	SA2712001	1	コードオサエ	CORD HOLDER	
18	062500816	1	ナベコ5X8	SCREW PAN M5X8	
19	J80990001	1	モ-タクミCDD-HT	MOTOR ASSY CDD-HT	
20	018501632	3	アナボルト5X16	BOLT SOCKET M5X16	
21	028050247	3	バネザガネ2-5	WASHER SPRING 2-5	
22	J03955001	1	ドラムコテイCDD	DRUM CDD	
23	014400632	2	アナクボミ4X6	SET SCREW SOCKET (CP) M4X6	
24	J03956001	1	ジシヤク180P36	MAGNET 180P36	
25	J03957001	1	MRセンサクミ180P	MR SENSOR ASSY 180P	
26	0A4301006	2	+ナベザクミ3X10DA	SCREW PAN (S/P WASHER) M3X10	
27	J03958001	1	シヤヘイイタCDD	SHIELD PLATE CDD	
28	0A4261006	3	+ナベザクミ26X10DA	SCREW PAN (S/P WASHE) M2.6X10	
29	0A4401005	1	+ナベザクミ4X10DA	SCREW, PAN (S/P WASHE) M4X10	
30	J80971001	1	CDD-ENCキバンクミ	PCB ASSY, CDD-ENC	
33	0A5300606	3	+ナベザクミ3X6DB	SCREW PAN (S/P WASHER) M3X6	
34	J04230001	1	コードオサエCDD-HT	CORD HOLDER CDD-HT	
35	0A4401006	2	+ナベザクミ4X10DA	SCREW PAN (S/P WASHE) M4X10	
36	J04296001	1	エンコ-ダカバ-CDD#2	ENCODER COVER CDD #2	
37	0A4300806	3	+ナベザクミ3X8DA	SCREW PAN (S/P WASHER) M3X8	
38	J03964001	1	プ-リトリツケタイクミCDD	PULLEY HOLDER ASSY CDD	
39	014500632	2	アナクボミ5X6	SET SCREW SOCKET (CP) M5X6	
40	SA2354001	5	+ナベセットネジ5X18	SCREW PAN M5X18	
41	SA3025001	3	ナベザクミ4X10DA	SCREW PAN (S/P WASHER) M4X10	
42	SA2687001	1	コードオサエ	CORD HOLDER	
43	062500816	1	ナベコ5X8	SCREW PAN M5X8	
44	SA8530001	1	トウブケンシユツユニット	HEAD DETECTOR UNIT	
45	062500816	2	ナベコ5X8	SCREW PAN M5X8	
46	028050246	2	バネザガネ2-5	WASHER SPRING 2-5	
47	026050136	2	ヒラザガネコガタ5	WASHER PLAIN S 5	
57	J04392001	1	LEDカバー	LED COVER	
48	BMP2060-0000000-CG40	1	< 中国向 > G40パネル	<For China Only> G-40-PANEL-CHINA	
48	BMP2060-0000000-0G40	1	< 中国・欧州以外向 > G40パネル	<Except for China and Europe> G-40-PANEL	
48	BMP2060-0000000-EG40	1	< 欧州向 > G40パネル	<For Europe Only> G-40-PANEL-EU	
49	J80973001	1	G40パネルキバンクミ	G40 PANEL PCB ASSY	
50	J80974001	1	G40サブキバンクミ	G40 SUB PCB ASSY	
51	J03975001	1	G40/パネルカザリイタ1	G40 PANEL SEAT 1	
52	J03976001	1	G40/パネルカザリイタ2	G40 PANEL SEAT 2	
53	J04195001	1	パネルトリツケイタ#2	PANEL SETTING PLATE#2	
54	J04273001	3	ナベザクミ4X10DB	SCREW PAN (S/P WASHER) M4X10	
55	J03983001	3	ホールICE W-400	HALL ELEMENT: ICE-400	
56	J03984001	2	ホールICE W-450	HALL ELEMENT: ICE-450	

< AC380-415V用  
/ For 380-415V AC >

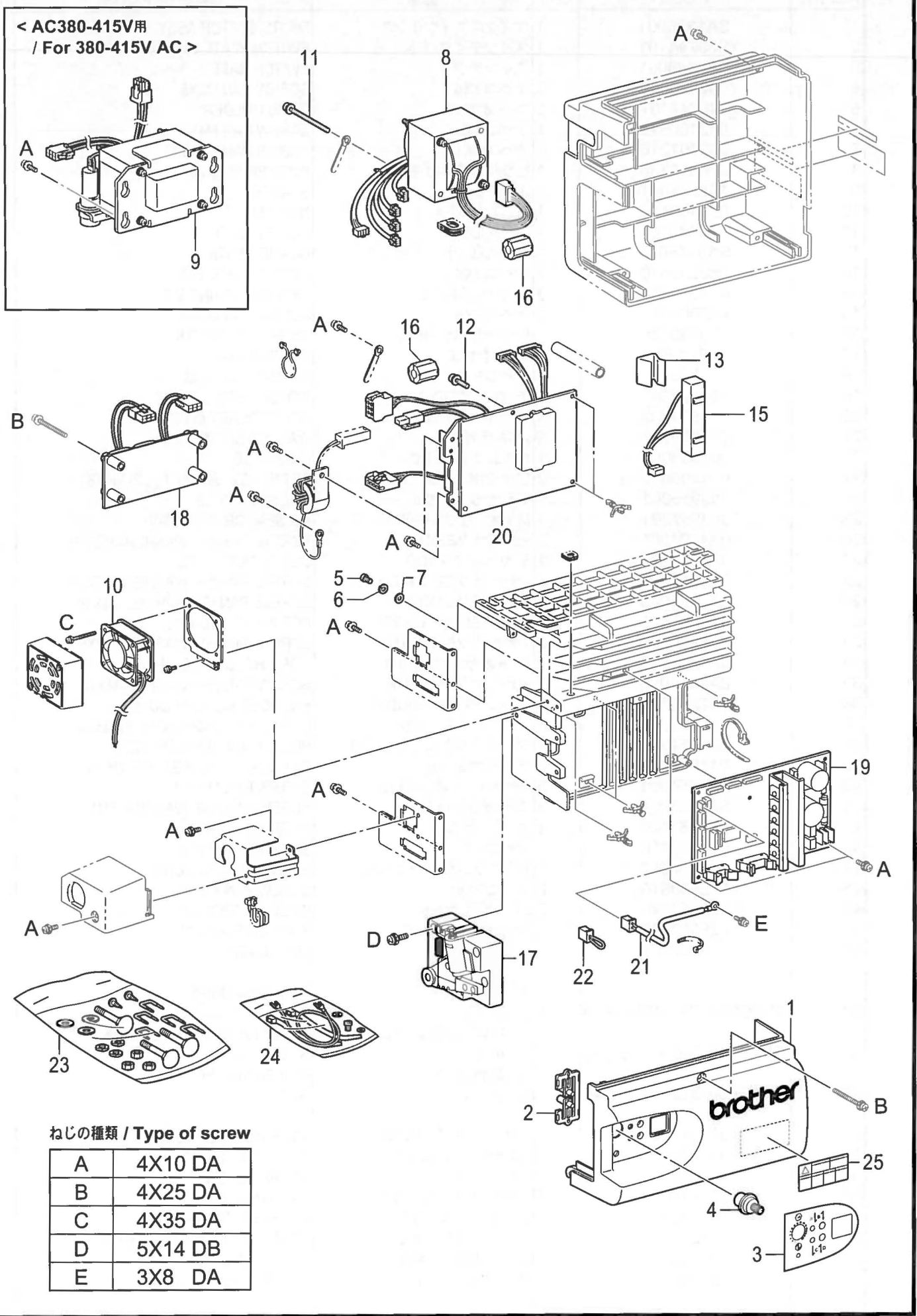

ねじの種類 / Type of screw

A	4X10 DA
B	4X25 DA
C	4X35 DA
D	5X14 DB
E	3X8 DA

## S2 . コントロールボックス関係 / Control box mechanism

REF.NO	CODE	Q'TY	品名	NAME OF PARTS	RM
1	J04393001	1	CDDマエフタGO	FRONT BOX COVER CDD GO	
2	J04438001	1	キートップ CDD-GO	KEY TOP	
3	J04440001	1	PカザリイタGO	PANEL SHEET CDD GO	
4	J04436001	1	VツマミLCA	SPEED ADJUST KNOB	
5	062400863	1	ナベコ4X8	SCREW PAN M4X8	
6	028040245	1	バネザガネ2-4	WASHER SPRING 2-4	
7	025040173	1	ヒラザガネシヨウ4	WASHER PLAIN S 4	
8	J04097001	1	<AC100 - 110V用> トランスCDD-100V	<For 100 - 110V AC> TRANSFORMER CDD-100V	
8	J04098001	1	<AC200 - 240V用> トランスCDD-200V	<For 200 - 240V AC> TRANSFORMER CDD-200V	
8	J04098001	1	<AC380 - 415V用> トランスCDD-200V	<For 380 - 415V AC> TRANSFORMER CDD-200V	
9	J04593001	1	トランス400V-SP	TRANSFORMER 400V-SP	
10	J04167001	1	DCファンCDDクミ#2	DC FAN ASSY, CDD #2	
11	J01411001	2	+ナベザクミ4X50DA	SCREW PAN (S/P WASHER) M4X50	
12	J00494001	2	+ナベセット4X14DA	SCREW PAN (S/P WASHER) M4X14	
13	J03739001	1	CRコテイイタ	SPRING PLATE, CR	
15	J04100001	1	セメントR40/220クミ#6	CEMENT RESISTOR ASSY 40/220 #6	
16	J04468001	2	<欧州向用> コアESD-SR-120	<For Europe> CORE: SD-SR-120	
17	J80967001	1	<前一段, 後一段タイプ> フミコミュニティCDD-コクホ	<Type forward 1 step, backward 1 step> TREADLE UNIT ASSY CDD G	
17	J80968001	1	<前二段, 後二段タイプ> フミコミュニティCDD-ユホ	<Type forward 2 step, backward 2 step> TREADLE UNIT ASSY CDD H	
18	J80970001	1	<欧州向用> CEフィルタキバンクミ	<For Europe> CE FILTER PCB ASSY	
19	J81008001	1	SキバンCDDクミ#GO-F	CONTROL PCB ASSY CDD #GO-F	
22	J04168001	1	<AC100 - 240V用> ショートコネクタ	<For 100 - 240V AC> SHORT CONNECTOR	
21	J04169001	1	<AC380 - 415V用> CDDサーミスタ#2	<For 380 - 415V AC> THERMISTOR, CDD #2	
20	J80965001	1	<AC100 - 110V用> DキバンCDD1-110Vクミ	<For 100 - 110V AC> POWER PCB ASSY, CDD 1-110V	
20	J80966101	1	<AC220 - 415V用> DキバンCDD1-230Vクミ	<For 220 - 415V AC> POWER PCB ASSY CDD 1-230V	
23	J04210001	1	カクネ8X65クミ	BOLT ASSY, SQUARE M8X65	
24	J04243001	1	アースコードネジタイクミ	EARTH CORD SCREW TIE ASSY	
25	J04115001	1	ラベルカンデン6カコク	LABEL, ELEC. SHOCK 6 LANG	

T. 逆転スイッチ関係 / Quick reverse switch mechanism

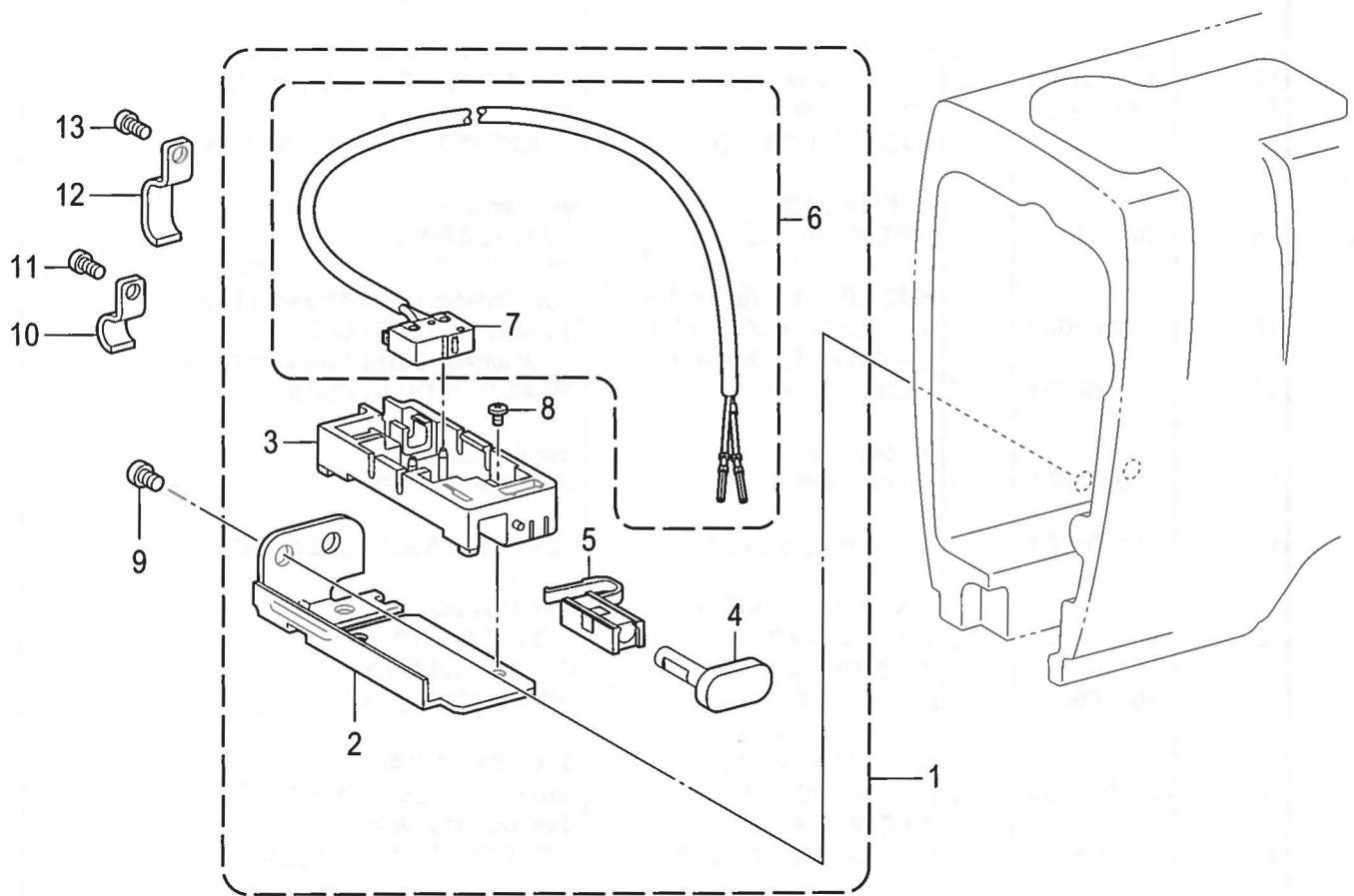

T-8421B/8422B-508

T. 逆転スイッチ関係 / Quick reverse switch mechanism

REF.NO	CODE	Q'TY	品名	NAME OF PARTS	RM
1	SA2688201	1	Rアクチュエータークミ	REVERSE ACTUATOR ASSY	
2	SA2270001	1	Rスイッチササエ	REVERSE SWITCH BRACKET	
3	S34281000	1	Rスイッチダイ	REVERSE SWITCH BRACKET	
4	SA4098101	1	アクチュエーター	ACTUATOR	
5	SA4099001	1	Rスイッチバネ	REVERSE SWITCH SPRING	
6	SA1390001	1	Rスイッチクミ	R-SWITCH ASSY	
7	S32907050	1	マイクロスイッチ	MICRO SWITCH	
8	060300606	1	バインド3X6	SCREW BIND M3X6	
9	062500616	2	ナベコ5X6	SCREW PAN M5X6	
10	SA2689101	1	コードオサエ	CORD HOLDER	
11	062500616	1	ナベコ5X6	SCREW PAN M5X6	
12	SA1388101	3	コードオサエ	CORD HOLDER	
13	062500616	1	ナベコ5X6	SCREW PAN M5X6	

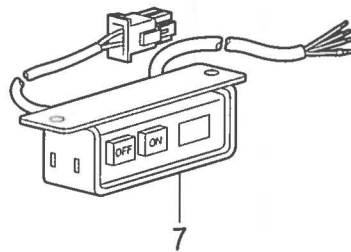
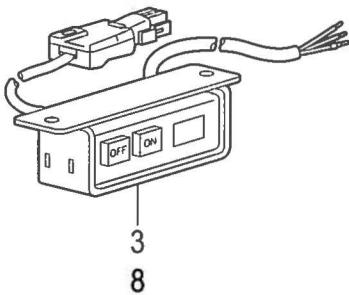
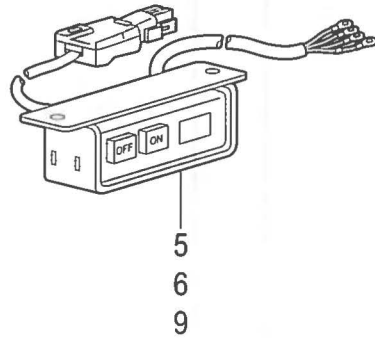
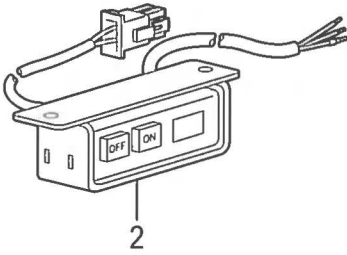
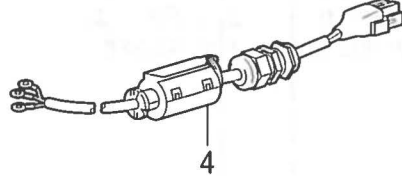
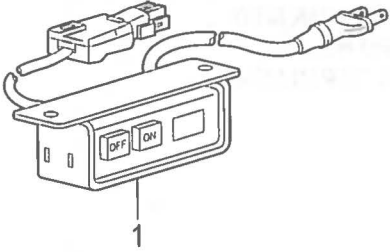



U . 電装品関係 / Power supply equipment mechanism

REF.NO	CODE	Q'TY	品名	NAME OF PARTS	RM
1	J04086001	1	<单相 100V AC用> <日本向用> デンSWクミ1-100V#6	<For Single phase 100V AC> < For Japan > POWER SWITCH ASSY 1-100V #6	
2	J04469001	1	<单相 110V AC用> <北米・メキシコ向用> デンSWクミ1-110V#8	<For Single phase 110V AC> < For USA, Canada & Mexico > POWER SWITCH ASSY 1-110V #8	
3	J04093001	1	<单相 220V AC用> <一般アジア・北アフリカ向用> デンSWクミ1-240V#6	<For Single phase 220V AC> < For General of Asia & North africa > POWER SWITCH ASSY 1-240V #6	
4	J04134001	1	<单相 230V AC CE 用> 電源スイッチ無 <欧州向用> デンPGクミ1-240V#6	<For Single phase 230V AC CE> Power SW-less < For Europe > POWER PLUG ASSY 1-240V #6	
5	J04096001	1	<三相 380V AC 用> <一般アジア・北アフリカ向用> デンSWクミ3-400V#6	<For Three phase 380V AC> < For General of Asia & North africa > POWER SWITCH ASSY 3-400V #6	
6	J04149001	1	<三相 200V AC 用> <日本向用> デンSWクミ3-200V#6	<For Three phase 200V AC> < For Japan > POWER SWITCH ASSY 3-200V #6	
7	J04470001	1	<三相 220V AC 用> <北米・メキシコ向用> デンSWクミ3-240V#8	<For Three phase 220V AC> < For USA, Canada & Mexico > POWER SWITCH ASSY 3-240V #8	
8	J04251001	1	<单相 220V AC用> <中国向用> デンSWクミ1-240V#CCC	<For Single phase 220V AC> < For China > POWER SWITCH ASSY 1-240V #CCC	
9	J04255001	1	<三相 380V AC 用> <中国向用> デンSWクミ3-400V#CCC	<For Three phase 380V AC> < For China > POWER SWITCH ASSY 3-400V #CCC	

V. 電磁押え上げセット関係 (オプション部品) / Presser foot lifting solenoid set mechanism (Option parts)

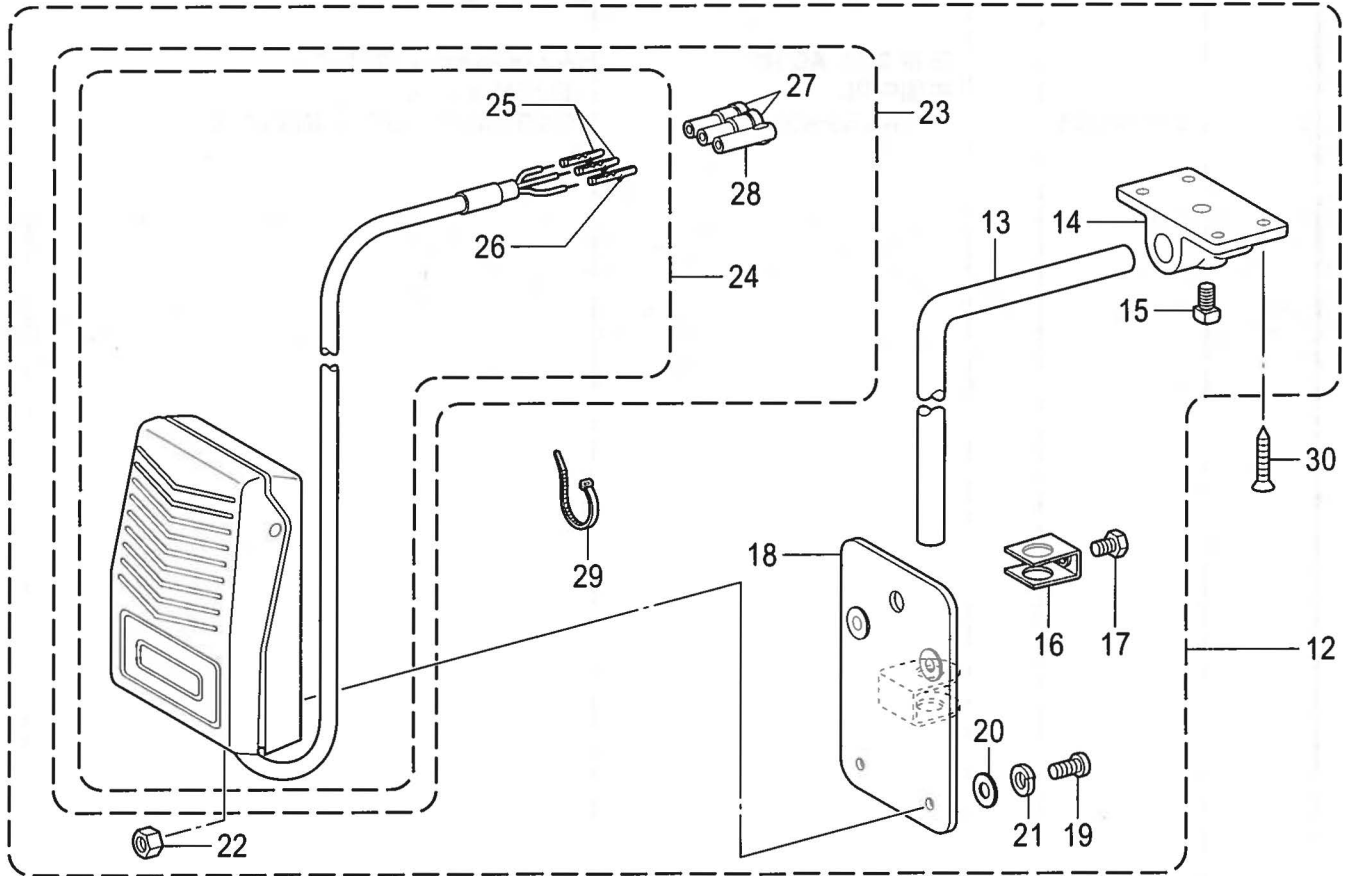
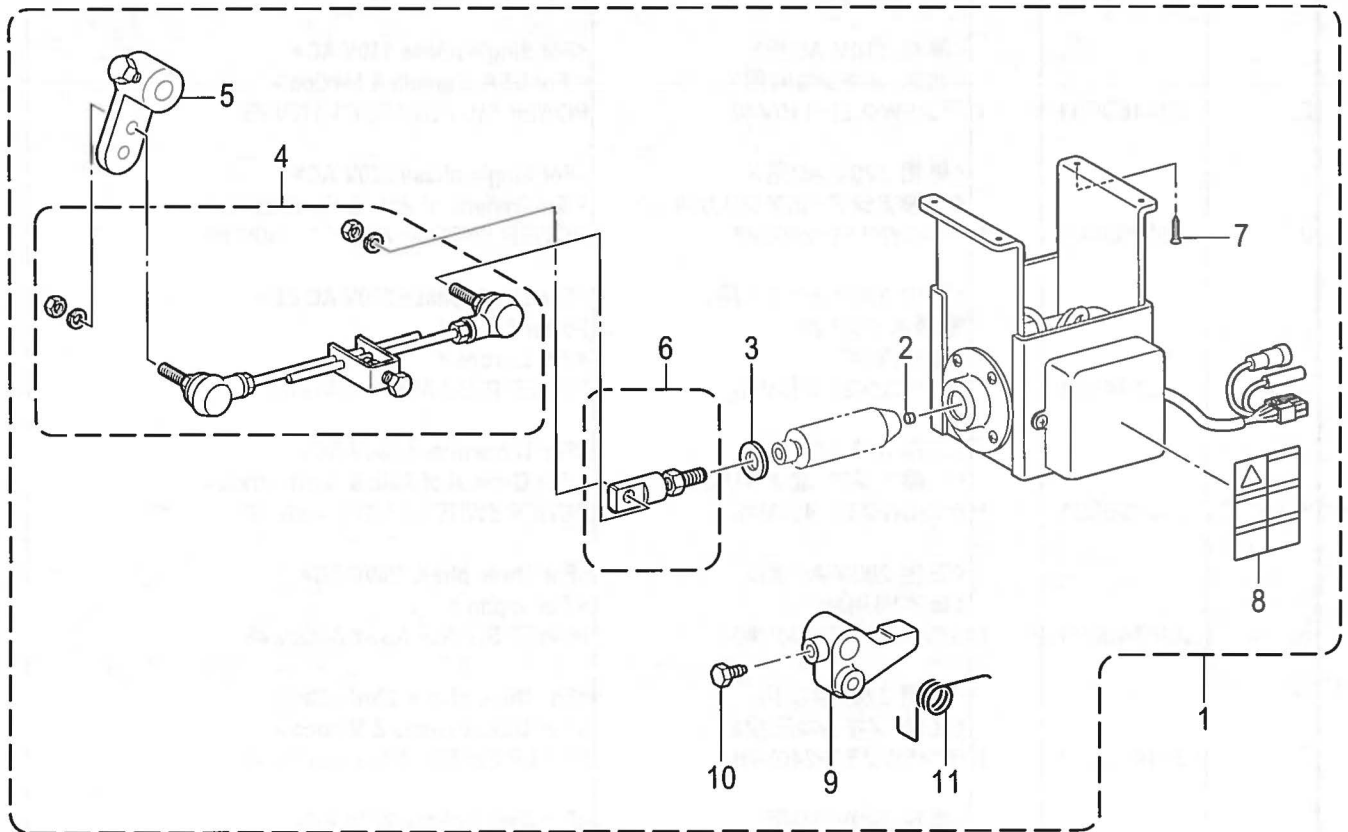

T-8421B/8422B-943

V. 電磁押え上げセット関係(オプション部品) / Presser foot lifting solenoid set mechanism (Option parts)

REF.NO	CODE	Q'TY	品名	NAME OF PARTS	RM
1	SA2707001	1	デンジオサエアゲセットD2	P-FOOT LIFTER SOLENOID SET, D2	
2	S54025001	1	クッション	CUSHION	
3	S54024001	1	クッションリング	CUSHION RING	
4	S42198051	1	オサエアゲロッドクミ	PRESSER FOOT LIFTER ROD ASSY	
5	S42199051	1	オサエアゲレバークミ	P-FOOT LIFTER LEVER ASSY	
6	S41955051	1	ロッドツギテクミ	ROD JOINT ASSY	
7	S42200051	4	モクネジ	WOOD SCREW	
8	S38351001	1	コウオンラベル	LABEL, HIGH TEMP	
9	S10550001	1	オサエアゲリンク	PRESSER BAR LIFTER LINK	
10	146367001	1	ボルト5.95	BOLT, SM5.95	
11	S07729001	1	ネジリバネ	SPRING, TWIST	
12	S07045009	1	ヒザスイッチクミ	KNEE LIFTER SWITCH ASSY	
13	142026003	1	ヒザスイッチタテジク	KNEE SWITCH SHAFT	
14	142027001	1	ヒザスイッチタテジクウケ	BRACKET	
15	100463001	1	4カクボルト7.94	BOLT, SQUARE SM7.94	
16	114967001	1	ヒザアテストツバ	KNEE LIFTER PLATE STOPPER	
17	110087001	1	ボルト5.95	BOLT, SM5.95-28X8	
18	S07027001	1	ヒザスイッチトリツケイタ	K-LIFTER SWITCH SETTING PLATE	
19	062401006	4	ナベコ4X10	SCREW PAN M4X10	
20	025040233	4	ヒラザガネチユウ4	WASHER, PLAIN M 4	
21	028040243	4	バネザガネ2-4	WASHER, SPRING 2-4	
22	021400164	4	1シュナツト4	NUT, 1 M4	
23	S07030009	1	スイッチコードクミ	SWITCH & HARNESS ASSY	
24	S07031009	1	フットスイッチクミ	FOOT SWITCH ASSY	
25	143549000	2	ピンターミナルオス	TERMINAL PIN, MALE	
26	143548000	1	ピンターミナルメス	TERMINAL PIN, FEMALE	
27	146046000	2	ナイロンコネクタ	NYLON CONNECTOR	
28	146194000	1	ナイロンコネクタ	NYLON CONNECTOR	
29	149799000	1	タイラツプS	BEAD BAND, S	
30	034422503	4	+2サラモク41X25	WOOD SCREW, FLAT 2 M4.1X25	

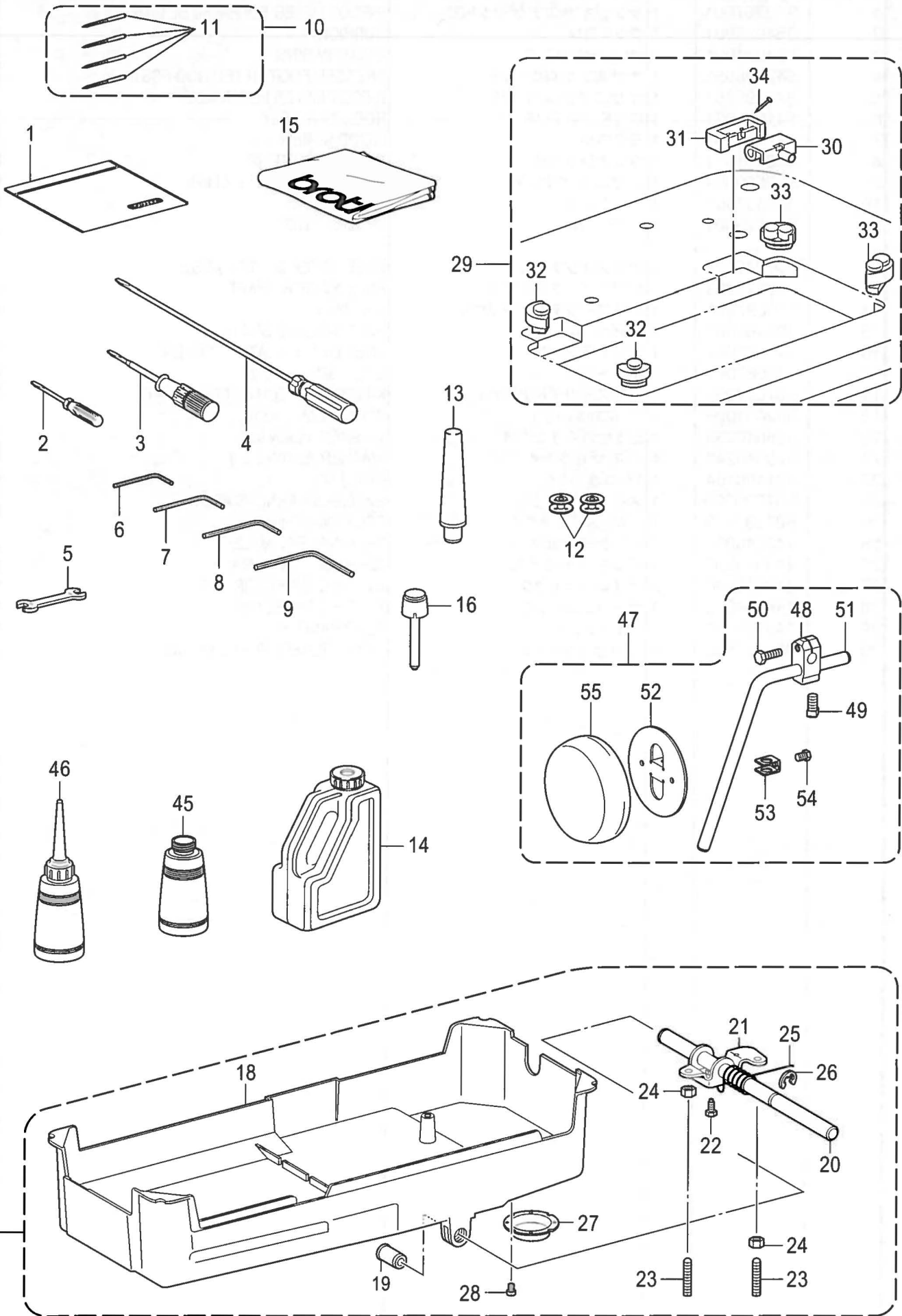

## Z1 . 付属品関係 / Accessories

REF.NO	CODE	QTY	品名	NAME OF PARTS	RM
1	122991001	1	フゾクヒンポリフクロ	ACCESSORY BAG	
2	142443001	1	ネジマワシ1.9X52	SCREW-DRIVER, 1.9X52	
3	118837001	1	ネジマワシ3.4X70	SCREW-DRIVER, 3.4X70	
4	S17774001	1	ネジマワシ4.7X250	SCREW-DRIVER, 4.7X250	
5	100887001	1	スパナ8X9	WRENCH, 8X9	
6	142002001	1	6カクボウスパナ2	HEXAGONAL WRENCH, 2	
7	154125001	1	6カクボウスパナ2.5	HEXAGONAL WRENCH, 2.5	
8	142721001	1	6カクボウスパナ3	HEXAGONAL WRENCH, 3	
9	149570001	1	6カクボウスパナ5	HEXAGONAL WRENCH, 5	
			<-□□3用>	<For -□□3>	
10	SA1752014	1	107415ハリ4コイリクミ	NEEDLE 4PIECE ASSY, 107415	
11	107415014	4	ミシンハリDPX5	NEEDLE, DPX5	
			<-□□5用>	<For -□□5>	
10	SA1752022	1	107415ハリ4コイリクミ	NEEDLE 4PIECE ASSY, 107415	
11	107415022	4	ミシンハリDPX5	NEEDLE, DPX5	
			<-□□F用>	<For -□□F>	
10	SA1752011	1	107415ハリ4コイリクミ	NEEDLE 4PIECE ASSY, 107415	
11	107415011	4	ミシンハリDPX5	NEEDLE, DPX5	
12	S01928151	2	ボビン	BOBBIN	
13	100477009	1	マクラ	HEAD REST	
14	S55663001	1	オイルタンククミ	OIL TANK ASSY	
15	144226001	1	トウブカバー	HEAD COVER	
16	145573000	1	ヒザアゲオシボウ	KNEE LIFTER COMPLYING BAR	
17	SA2691101	1	アブラウケクミ	OIL PAN ASSY	
18	SA2692101	1	アブラウケ	OIL PAN	
19	149578000	2	ヨコジクブツシュ	BUSH	
20	SA2582001	1	ヒザアゲヨコジク	KNEE LIFTER SHAFT	
21	SA2590001	1	ヒザアゲ	KNEE LIFTER	
22	S25344001	1	ボルト6	BOLT M6	
23	S25475101	2	トメネジ6	SET SCREW, M6X19	
24	021060306	2	3シユナツト6	NUT 3 M6	
25	S15889001	1	ヒザアゲネジリバネ	TWIST SPRING	
26	146293001	1	トメワE10	RETAINING RING, E10	
27	153230101	1	オイルニガシグチ	DRAIN	
28	S23418002	2	シメネジ4X5	SCREW, M4X5	
29	SA1969001	1	ラバーヒンジクミ	RUBBER HINGE ASSY	
30	143882001	2	トウブヒンジ	HEAD HINGE	
31	143910009	2	トウブヒンジウケゴム	RUBBER CUSHION	
32	SA1962001	2	トウブシキゴム	HEAD CUSHION	
33	SA1963001	2	トウブシキゴム	HEAD CUSHION	
34	109714000	4	クギ	NAIL	
45	114486002	1	ポリオイラータイ	OILER	
46	114483002	1	ポリオイラークミ	OILER ASSY	
47	S38300001	1	ヒザアテクミ	KNEE LIFTER ASSY	
48	146039121	1	ヒザアテツギテ	KNEE LIFTER BRACKET	
49	100463021	1	4カクボルト7.94	BOLT, SQUARE SM7.94	
50	S35820021	1	ボルト5.95X20	BOLT, SM5.95X20	
51	S38278001	1	ヒザアゲタテジク	KNEE LIFTER BAR	
52	S34756021	1	ヒザアテ	KNEE LIFTER PLATE	
53	114967021	1	ヒザアテストツパ	KNEE LIFTER PLATE STOPPER	
54	110087021	1	ボルト5.95	BOLT, SM5.95-28X8	
55	S31885001	1	ヒザアテカバー	KNEE LIFTER PLATE COVER	

T-8421B/8422B-910

From the library of: Superior Sewing Machine &amp; Supply LLC

56

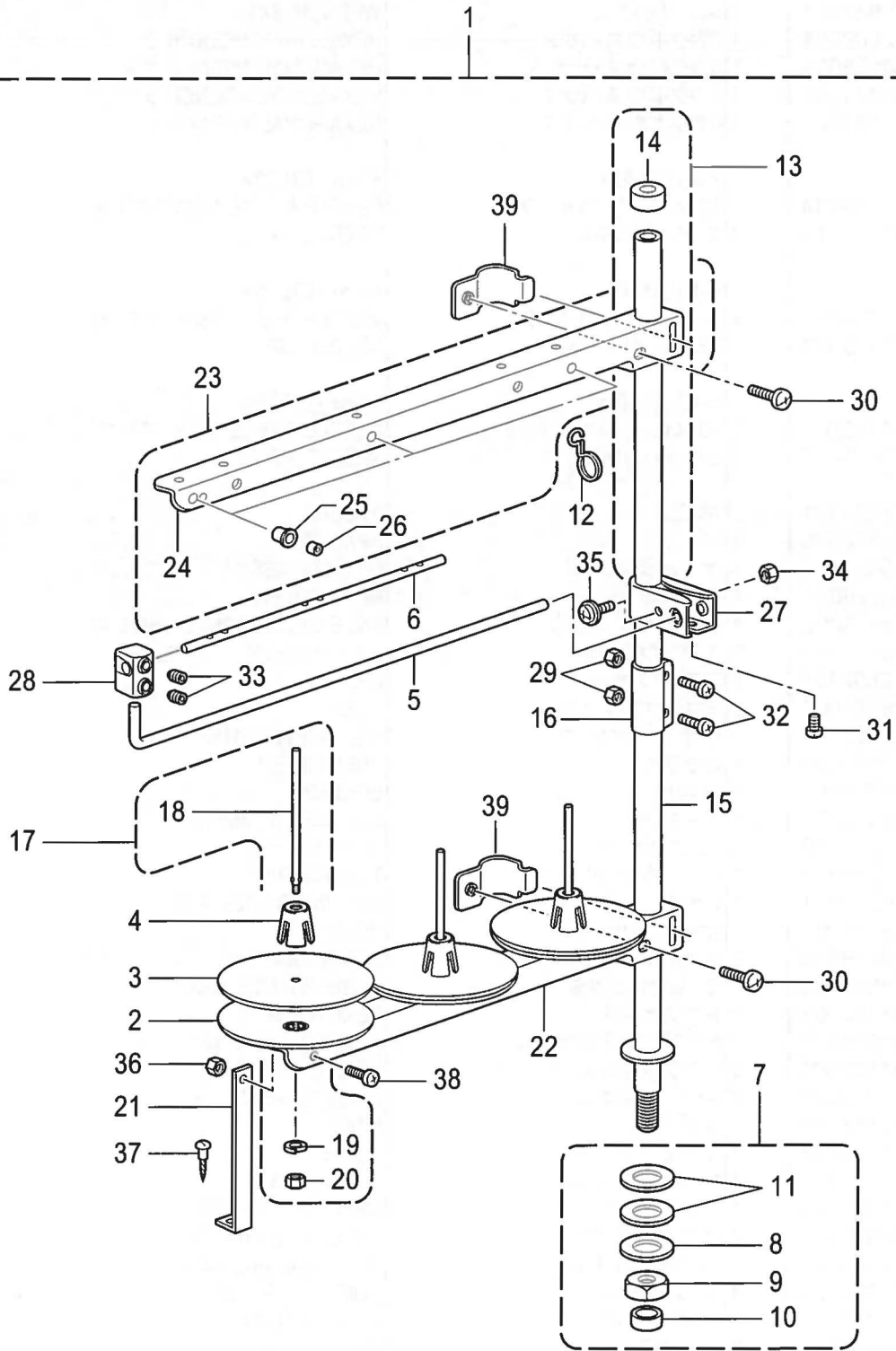

## Z2. 付属品関係 / Accessories

REF.NO	CODE	Q'TY	品名	NAME OF PARTS	RM
1	S07558409	1	イトタテダイクミ3DRTHF	COTTON STAND ASSY 3DRTHF	
2	S51283001	3	ウケザラ	SPOOL STAND BASE	
3	150182000	3	スプールマット	SPOOL MAT	
4	S51282101	3	スプールクッション	SPOOL CUSHION	
5	S04109001	1	イトアンナイササエボウ	THREAD GUIDE SUPPORT BAR	
6	142997001	1	イトアンナイ3	THREAD GUIDE, 3	
7	SA6627001	1	パイプDネジセットB	PIPE D SCREW SET B	
8	150206002	1	ヒラザガネ16	WASHER, PLAIN 16	
9	SA6629001	1	6カクナツM16	NUT M16	
10	150174000	1	コラムキャップ	COLUMN CAP	
11	S01005000	2	イトタテゴム	RUBBER WASHER	
12	S02747101	1	イトカケバネ	SPRING	
13	S40639001	1	コラムパイプキャップツキ	COLUMN PIPE W/CAP	
14	150174000	1	コラムキャップ	COLUMN CAP	
15	156112003	1	コラムパイプD	COLUMN PIPE D	
16	SA6606001	1	コラムジョイント	COLUMN JOINT	
17	S21798001	3	スプールネジセット	SPOOL & SCREW SET	
18	150179002	3	スプールジクB	SPOOL SHAFT B	
19	028050244	3	バネザガネ2-5	WASHER SPRING 2-5	
20	021500104	3	1シュナツ5	NUT 1 M5	
21	150188009	1	スプールホルダーササエA	SPOOL HOLDER SUPPORT, A	
22	SA6610001	1	スプールホルダー3	SPOOL HOLDER 3	
23	SA6611001	1	スレツドハンガークミ3	THREAD HANGER ASSY 3	
24	SA6610001	1	スプールホルダー3	SPOOL HOLDER 3	
25	150183000	3	イトカケハンガーダイ	THREAD HANGER BASE	
26	142990001	3	スレツドブツシュ	THREAD BUSH	
27	SA6615001	1	イトアンナイホルダー	THREAD GUIDE HOLDER	
28	138843001	1	ササエボウツギテ	JOINT	
29	021500104	2	1シュナツ5	NUT 1 M5	
30	062061604	2	ナベコ6X16	SCREW PAN M6X16	
31	S37037001	1	ナベコヒラザ5X32	SCREW PAN (S/P WASHER) M5X32	
32	062501404	2	ナベコ5X14	SCREW PAN M5X14	
33	014060632	2	アナクボミ6X6	SET SCREW SOCKET (CP) M6X6	
34	021500104	1	1シュナツ5	NUT 1 M5	
35	S37037001	1	ナベコヒラザ5X32	SCREW PAN (S/P WASHER) M5X32	
36	021500104	1	1シュナツ5	NUT 1 M5	
37	031452204	1	マルモク45X22	WOOD SCREW ROUND M4.5X22	
38	062501004	1	ナベコ5X10	SCREW PAN M5X10	
39	SA6609001	2	スプールホルダーササエ	SPOOL HOLDER SUPPORTER	

Wa. 警告ラベル / Warning labels

警告ラベル / Warning labels	品名 / Name of parts	Size(mm)	Code
	<p>ラベル感電6ヶ国 Label, elec. shock 6 lang</p>	<p>50 X 118</p>	<p>J04115-001</p>
	<p>ラベル注意・和英 Label, caution Jpn / Eng</p>	<p>64 X 40</p>	<p>SA2040-001</p>
	<p>ラベル注意・中英 Label, caution Chn / Eng</p>	<p>64 X 40</p>	<p>SA2041-001</p>
	<p>アースマーク Label, grounding</p>	<p>φ 12</p>	<p>S37060-001</p>
	<p>高温ラベル Label, high temp</p>	<p>72 X 59</p>	<p>S38351-001</p>

T-8421B/8422B-Wa



## T-8421B (糸切りなし) / T-8421B (Without Thread trimmer)

## ■ かま / Rotary hooks

かまは下記のオプションパーツを用意しています。用途に合わせてご使用ください。  
(部品コードは、かまが箱に入った組コードです)

The following type of rotary hook are available. Select whichever one is suitable for your application.  
(The following parts codes are assigned for the rotary hooks in the boxes.)

## ● 標準 / Normal

	-□□F,-□□3用 / For -□□F,-□□3	-□□5用 / For -□□5
かま箱組 / Rotary hook assy	SA1668-111	SA1669-111
調子バネ / Tension spring	151145-001	151146-001
調子ネジ / Tension adjusting screw	151029-001	151029-001

## ● オプション / Option

## ○ キャップ付 / Rotary hook with cap

	-□□F,-□□3用 / For -□□F,-□□3
かま箱組 / Rotary hook assy	SA1670-111
キャップ組 / Bobbin case assy	S07740-001
調子バネ / Tension spring	154518-001
調子ネジ / Tension adjusting screw	154519-001

## ○ オープン給油 / Extra lubrication rotary hook

かまへの油量が多いので、レース部の磨耗を防ぎます。厚物や極厚物の縫製に適しています。

Sufficient oil supplied to the rotary hook to prevent wear of the rotary hook race.

This type is suitable for sewing heavy and extra heavy materials.

	-□3□用 / For -□3□	-□5□用 / For -□5□
かま箱組 / Rotary hook assy	SA1671-111	SA1672-111
調子バネ / Tension spring	151145-001	151146-001
調子ネジ / Tension adjusting screw	151029-001	151029-001

## ○ 剣先強化 / Rotary hook with reinforced hook point

かまの剣先を強化し、剣先の磨耗を防ぎます。ループのできにくい素材（伸縮性のあるものなど）の縫製で、かまの剣先を針に接触させて使うような場合に適しています。

The rotary hook point is reinforced to improve its durability. This type is suitable for sewing materials that are hard to make loops on the surface ( like stretchy materials ), and that requires making contact with the hook point and the needles.

	-□□F,-□□3用 / For -□□F,-□□3
かま箱組 / Rotary hook assy	SA1673-011
調子バネ / Tension spring	151145-001
調子ネジ / Tension adjusting screw	151029-001

## ○ RPがま / RP rotary hook

給油が不要ですので、給油の煩わしさがありません。特に、縫製物や糸の油汚れを解消するのに最適です。

Lubrication is not needed. This is the most useful to prevent oil stains on material and thread.

	-□□F,-□□3用 / For -□□F,-□□3
かま箱組 / Rotary hook assy	SA1674-102
調子バネ / Tension spring	151145-001
調子ネジ / Tension adjusting screw	151029-001

## T-8422B (糸切り) / T-8422B (With Thread trimmer)

## ■ かま / Rotary hooks

かまは下記のオプションパーツを用意しています。用途に合わせてご使用ください。  
(部品コードは、かまが箱に入った組コードです)

The following type of rotary hook are available. Select whichever one is suitable for your application.  
(The following parts codes are assigned for the rotary hooks in the boxes.)

## ● 標準 / Normal

	全仕様 / For all type
かま箱組 / Rotary hook assy	SA1677-111
調子バネ / Tension spring	151145-001
調子ネジ / Tension adjusting screw	151029-001

## ● オプション / Option

## ○ キャップ付 / Rotary hook with cap

	-□□F,-□□3用 / For -□□F,-□□3
かま箱組 / Rotary hook assy	SA1678-111
キャップ組 / Bobbin case assy	S07740-001
調子バネ / Tension spring	154518-001
調子ネジ / Tension adjusting screw	154519-001

## ○ 剣先強化 / Rotary hook with reinforced hook point

かまの剣先を強化し、剣先の磨耗を防ぎます。ループのできにくい素材（伸縮性のあるものなど）の縫製で、かまの剣先を針に接触させて使うような場合に適しています。

The rotary hook point is reinforced to improve its durability. This type is suitable for sewing materials that are hard to make loops on the surface ( like stretchy materials ), and that requires making contact with the hook point and the needles.

	-□□F,-□□3用 / For -□□F,-□□3
かま箱組 / Rotary hook assy	SA1679-011
調子バネ / Tension spring	151145-001
調子ネジ / Tension adjusting screw	151029-001

## ○ RPがま / RP rotary hook

給油が不要ですので、給油の煩わしさがありません。特に、縫製物や糸の油汚れを解消するのに最適です。  
Lubrication is not needed. This is the most useful to prevent oil stains on material and thread.

	-□□F,-□□3用 / For -□□F,-□□3
かま箱組 / Rotary hook assy	SA3922-101
調子バネ / Tension spring	151145-001
調子ネジ / Tension adjusting screw	151029-001

**T-8421B (糸切りなし) / T-8421B (Without Thread trimmer)**

**標準品 / For Normal**

針幅 Needle gauge	針抱き組 Needle clamp assy	針板 Needle plate		送り歯 Feed dog	押え組 Presser foot assy
		中厚,厚物用 (-3,-5) 最大 5mmピッチ For medium & heavy materials (Max 5mm pich)	オプション 最大 4mmピッチ Option (Max 4mm pich)		
1.6mm (1/16)	158808-001		142111-001	151078-001	151076-001
3.2mm (1/8)	158794-101	117369-001	114950-001	114951-001	S36544-001
4.0mm (5/32)	158796-101	150850-001	116503-001	116509-001	116502-001
4.8mm (3/16)	158791-101	117133-001	112603-001	112659-001	SA4053-101
6.4mm (1/4)	158792-101	117367-001	112604-001	112660-001 SA7665-001	SA4049-101
7.9mm (5/16)	158793-101	144882-001	112605-001	112661-001	112645-001
9.5mm (3/8)	158798-101	144881-101	116506-101	116510-101	116498-001
11.1mm (7/16)	158809-101		151596-001	151598-001	151597-101
12.7mm (1/2)	158797-101	S09365-001	116505-001	116511-001	116499-101
15.9mm (5/8)	158795-101	159577-001	116507-001	116512-001	116500-101
25.4mm (1)	158805-101		147176-001	147178-001	147177-101
31.8mm (1 1/4)	158799-101		116504-001	116508-001	116501-101
34.9mm (1 3/8)	S10746-101	S14148-001		S14149-001	S10751-101
38.1mm (1 1/2)	158800-101		118945-001	118947-001	118946-101

**ファンデーション用 / For foundation**

- \* 針板と送り歯が標準品と異なります。針板取付用サラネジは 117160-001(H-5) を使用して下さい。
- \* The needle plate and the feed dog is different from normal parts.  
Use part no. 117160-001(H-5) as the needle plate installation screw.

針幅 Needle gauge	針抱き組 Needle clamp assy	針板 Needle plate	送り歯 Feed dog	押え組 Presser foot assy
3.2mm (1/8) サン無し / Bar less	標準品 / Normal	S24571-001	S24572-001	標準品 / Normal
4.8mm (3/16)		117158-001	117134-001	
6.4mm (1/4)		117368-001	117365-001	
7.9mm (5/16)		S31907-001	S31908-001	

**空縫い用 / For sewing without material**

- \* 針板と送り歯と押え組が標準品と異なります。最大送りピッチは4mm以下でご使用下さい。
- \* Needle plate, the feed dog and presser foot assembly is different from normal parts.  
Use gauge components of for sewing without material which have a maximum feed pitch of 4mm or less.

針幅 Needle gauge	針抱き組 Needle clamp assy	針板 Needle plate	送り歯 Feed dog	押え組 Presser foot assy
4.8mm (3/16)	標準品 / Normal	S36010-101	S36011-101	S36012-001
6.4mm (1/4)		S36025-001	S36024-001	S36022-001

**T-8421B (糸切りなし) / T-8421B (Without Thread trimmer)**

**標準品 / For Normal**

針抱き組 Needle clamp assy	針板 Needle plate	
	中厚,厚物用 (-3,-5) (最大5mmピッチ) For medium & heavy materials (Max 5mm pich)	オプション(最大4mmピッチ) Option (Max 4mm pich)
送り歯 Feed dog	押え組 Presser foot assy	
中厚,厚物用 (-3,-5) For medium & heavy materials		

**ファンデーション用 / For foundation**

針板 Needle plate	送り歯 Feed dog

**空縫い用 / For sewing without material**

針板 Needle plate	送り歯 Feed dog	押え組 Presser foot assy

**T-8421B (糸切りなし) / T-8421B (Without Thread trimmer)**

**薄物用 / For light materials**

- \* 送り歯が標準品と異なります。
- \* The feed dog is different from normal parts.

針幅 Needle gauge	針抱き組 Needle clamp assy	針板 Needle plate	送り歯 Feed dog	押え組 Presser foot assy
3.2mm (1/8)	標準品 / Normal	標準品 / Normal	S07880-001	標準品 / Normal
4.8mm (3/16)			S07878-001	
6.4mm (1/4)			S07879-001	

**厚物用 / For heavy materials**

- \* 送り歯が標準品と異なります。
- \* The feed dog is different from normal parts.

針幅 Needle gauge	針抱き組 Needle clamp assy	針板 Needle plate	送り歯 Feed dog	押え組 Presser foot assy
4.8mm (3/16)	標準品 / Normal	標準品 / Normal	S21149-001	標準品 / Normal
6.4mm (1/4)			S21150-001	

**極厚物用 / For extra heavy materials**

- \* 送り歯が標準品と異なります。
- \* The feed dog is different from normal parts.

針幅 Needle gauge	針抱き組 Needle clamp assy	針板 Needle plate	送り歯 Feed dog	押え組 Presser foot assy
3.2mm (1/8)	標準品 / Normal	標準品 / Normal	158430-001	標準品 / Normal
4.8mm (3/16)			S13588-001	
6.4mm (1/4)			153882-001	
9.5mm (3/8)			153887-001	
12.7mm (1/2)			153892-001	
15.9mm (5/8)			153897-001	

**極薄物用 / For extra light materials**

- \* 送り歯と押えが標準品と異なります。
- \* 押え組の形状は標準品と同じですが、特殊な表面処理が施してあります。
- \* The feed dog and presser foot assembly is different from normal parts.
- \* The shape of the presser foot assembly is the same as for the standard part, but it has a special surface processing.

針幅 Needle gauge	針抱き組 Needle clamp assy	針板 Needle plate	送り歯 Feed dog	押え組 Presser foot assy
4.8mm (3/16)	標準品 / Normal	標準品 / Normal	S36832-001	S36833-001
6.4mm (1/4)			S36829-001	S36830-001

**T-8421B (糸切りなし) / T-8421B (Without Thread trimmer)****オプション部品 / Option parts**

\* 押え組が標準品と異なります。案内付押えは、最大送りピッチ 4mm 以下でご使用下さい。

\* The presser foot assembly is different from normal parts.

The presser foot assembly with guide should be used with a maximum feed pitch of 4mm or less.

品名 Name of parts	針幅 Needle gauge	針抱き組 Needle clamp assy	針板 Needle plate	送り歯 Feed dog	押え組 Presser foot assy
案内付き押え組 Presser foot assy with guide	3.2mm (1/8)	標準品 / Normal	標準品 / Normal	標準品 / Normal	149311-001
	4.8mm (3/16)				117281-001
	6.4mm (1/4)				149312-001
左案内付き押え Presser foot assy with guide, L	7.9mm (5/16)				S13735-001
ファスナー付け用 Presser foot assy for attach zipper (Right)	3.2mm (1/8)				S14080-001
左ファスナー付け用 Presser foot assy for attach zipper (Left)	3.2mm (1/8)				S33459-001

**T-8421B (糸切りなし) / T-8421B (Without Thread trimmer)**

**薄物用 / For light materials**

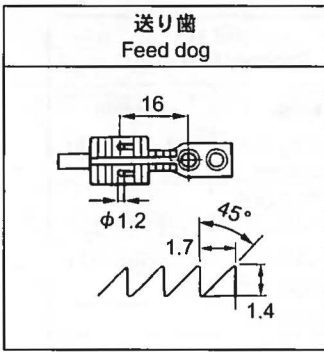

**厚物用 / For heavy materials**

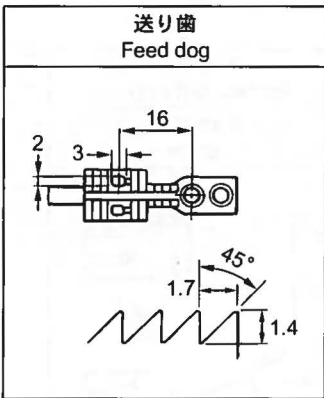

**極厚物用 / For extra heavy materials**

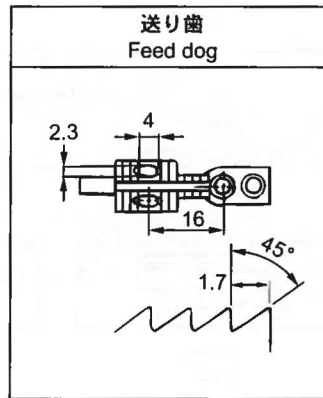

**極薄物用 / For extra light materials**

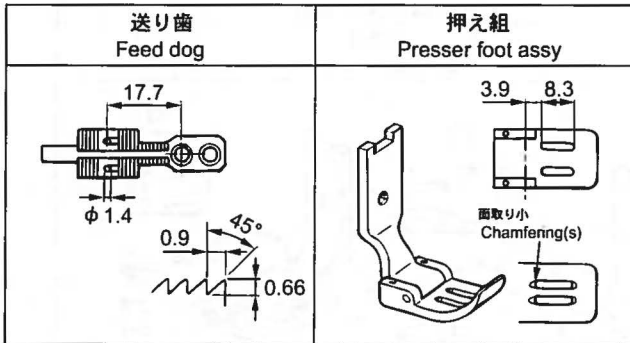

**オプション部品 / Option parts**

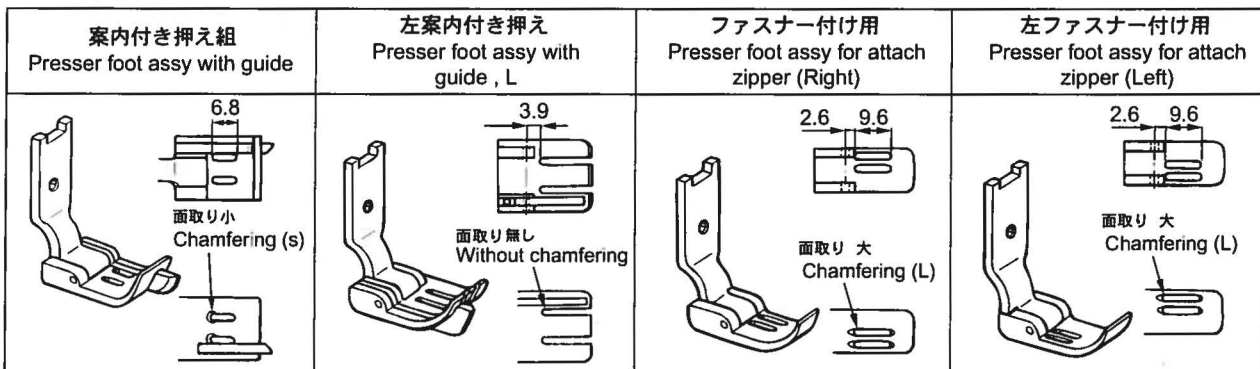

**T-8421B (糸切りなし) / T-8421B (Without Thread trimmer)**

下送り用 / For drop Feed

針幅 Needle gauge	針抱き組 Needle clamp assy	針板 Needle plate		送り歯 Feed dog		押え組 Presser foot assy	
		薄物用 For light materials	極薄物用 For extra light materials	薄物用 For light materials	極薄物用 For extra light materials	薄物用 For light materials	極薄物用 For extra light materials
3.2mm (1/8)	158794-101	S07686-001		S07696-001		S38544-001	
4.8mm (3/16)	158791-101	S07688-001	S36842-001	S07698-001	S36838-001	S38542-001	S36839-001
6.4mm (1/4)	158792-101	S07689-001	S36841-001	S07699-001	S36835-001	S38543-001	S36836-001
12.7mm (1/2)	158797-101	S07693-001		S07703-001		S07684-101	
19.1mm (3/4)	158806-101	S07996-001		S07998-001		S07889-101	
20mm	S00937-001	S13479-001		S07998-001		S13480-101	
22.2mm (7/8)	158807-101	S07997-001		S07999-001	S07999-001	S07894-101	

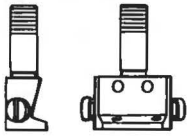
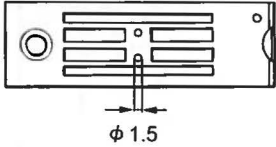
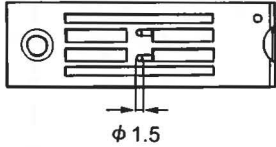
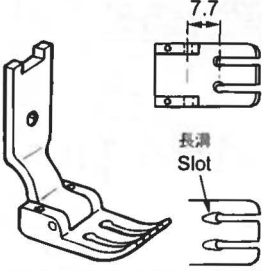
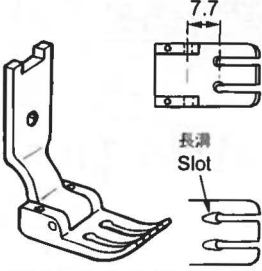
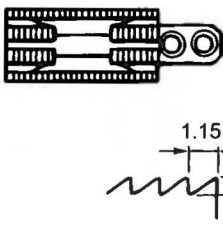
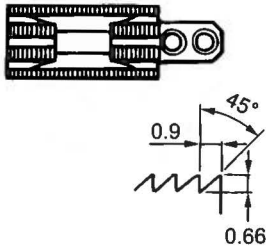
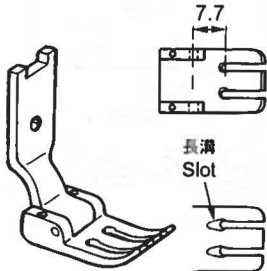
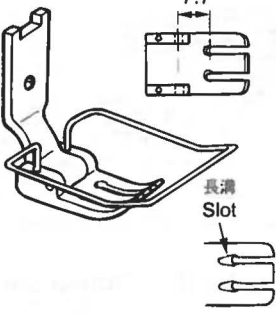
針抱き組 Needle clamp assy	針板 Needle plate		押え組 Presser foot assy	
	薄物用 For light materials	極薄物用 For extra light materials	極薄物用 For extra light materials	極薄物用 For extra light materials
				
	送り歯 Feed dog		押え組 Presser foot assy	
	薄物用 For light materials	極薄物用 For extra light materials	薄物用 For light materials	
				



**T-8421B (糸切りなし) / T-8421B (Without Thread trimmer)**

前立て用 / For shirt fronts

針幅 Needle gauge	針抱き組 Needle clamp assy	針板 Needle plate	送り歯 Feed dog	押え組 Presser foot assy
		薄物用 For light materials	薄物用 For light materials	薄物用 For light materials
18mm	S14352-001	S14354-001	S14357-001	S14355-101
20mm	S00937-001	S13479-001	S14360-001	S14358-101
22mm	158807-101	S07997-001	S14363-001	S14361-101
24mm	S14364-001	S14366-001	S14369-001	S14367-101
26mm	S14370-001	S14372-001	S14375-001	S14373-101
28mm	S14376-001	S14378-001	S14381-001	S14379-101
30mm	S16651-001	S16653-001	S16656-001	S16654-101

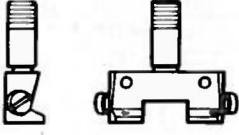
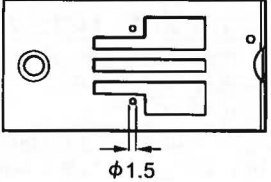
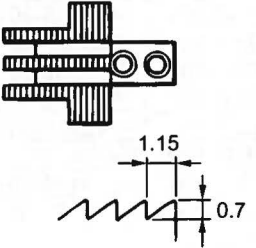
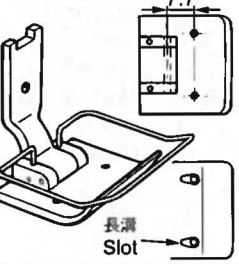
針抱き組 Needle clamp assy	針板 Needle plate	送り歯 Feed dog	押え組 Presser foot assy
	薄物用 For light materials	薄物用 For light materials	薄物用 For light materials
	 <p>φ1.5</p>	 <p>1.15 0.7</p>	 <p>7.7 長溝 Slot</p>

## T-8422B (糸切り) / T-8422B (With Thread trimmer)

## 標準品 / For Normal

\* 糸切り用固定刃(S07527-001)と取付ネジ(148539-101)は、針板には付けてありませんので、必要に応じて別途ご注文下さい。

\* The thread trimming fixed knife (part No. S07527-001) and the installation screw (part No. 148539-101) are not provided with the needle plate, so they must be ordered separately if required.

針幅 Needle gauge	針抱き組 Needle clamp assy	針板 Needle plate		送り歯 Feed dog		押え組 Presser foot assy	
		中厚・厚物用 (-3,-5) 最大5mmピッチ For medium & heavy materials (Max 5mm pitch)	オプション 最大4mmピッチ Option (Max 4mm pitch)	中厚物用 (-3) For medium materials	厚物用 (-5) For heavy materials	中厚物用 (-3) For medium materials	厚物用 (-5) For heavy materials
2mm	S19862-001	S19864-001			S19866-001		S19867-001
2.4mm (3/32)	158804-101	159398-001			148697-001		148679-001
2.8mm	S19905-001	S19907-001			S19909-001		S19910-001
3.2mm (1/8)	158794-101	155722-001	159400-001	148698-001	148699-001	S36550-001	S36552-001
4.0mm (5/32)	158796-101	155724-001	158785-001	148700-001	148701-001	148689-001	148683-001
4.8mm (3/16)	158791-101	155851-001	158784-001	148702-001	148703-001	S36554-001	S36556-001
6.4mm (1/4)	158792-101	155853-001	158783-001	148704-001	148705-001	SA4051-001	SA4050-101
7.9mm (5/16)	158793-101	155855-001	159402-001	149692-001	149691-001	149689-001	149687-001
9.5mm (3/8)	158798-101	155857-001	149946-001	149939-001	149938-001	149942-001	149940-001
11.1mm (7/16)	158809-101	S01644-001		S01646-001		S01641-101	
12.7mm (1/2)	158797-101	149677-001	159404-001	149676-001	149675-001	149673-101	149671-101
15.9mm (5/8)	158795-101	149954-001	149956-001	149949-001	149948-001	149952-101	149950-101
19.1mm (3/4)	158806-101	150526-001			150523-001		150524-101
22.2mm (7/8)	158807-101	150534-001			150531-001		150532-101
25.4mm (1)	158805-101	149966-001	S32052-001	S32054-001	149960-001	S32055-101	149962-101
28.6mm (1 1/8)	S16102-001		S16104-001	S16106-001		S16107-101	
38.1mm (1 1/2)	158800-101	S07391-001			S07390-001		S07388-101

## 空縫い用 / For sewing without material

\* 針板と送り歯と押え組が標準品と異なります。最大送りピッチは4mm以下でご使用下さい。

\* Needle plate, the feed dog and presser foot assembly is different from normal parts.  
Use gauge components of for sewing without material which have a maximum feed pitch of 4mm or less.

針幅 Needle gauge	針抱き組 Needle clamp assy	針板 Needle plate	送り歯 Feed dog	押え組 Presser foot assy
4.8mm (3/16)	標準品 / Normal	S20901-001	S20905-001	S20903-001
6.4mm (1/4)		S10507-001	S10509-101	S10510-001
22.2mm (7/8)		S14538-001	S14540-101	S14541-101
25.4mm (1)		S14543-001	S14545-001	S14546-101

T-8422B (糸切り) / T-8422B (With Thread trimmer)

標準品 / For Normal

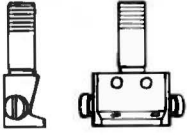
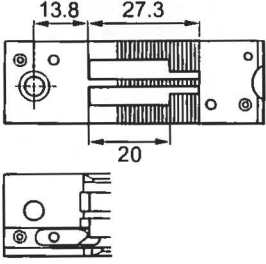
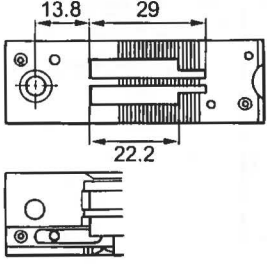
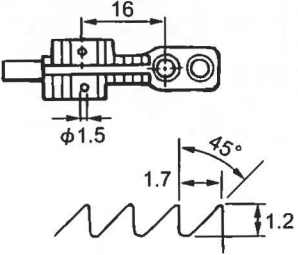
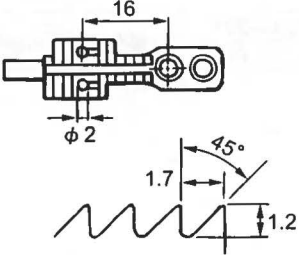
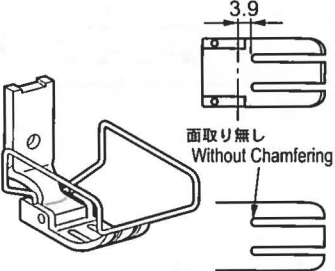
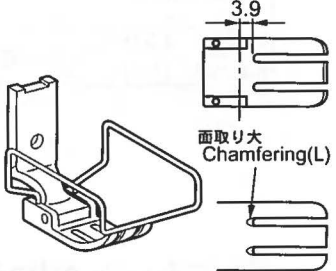
針抱き組 Needle clamp assy	針板 Needle plate			
	中厚物用 (-3) For medium materials	厚物用 (-5) For heavy materials		
				
送り歯 Feed dog		押え組 Presser foot assy		
中厚物用 (-3) For medium materials	厚物用 (-5) For heavy materials	中厚物用 (-3) For medium materials	厚物用 (-5) For heavy materials	
				

空縫い用 / For sewing without material

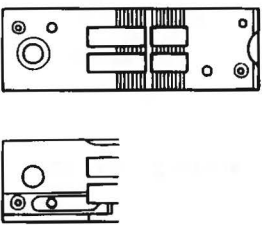
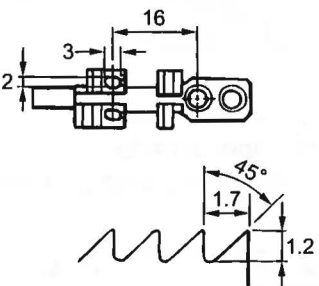
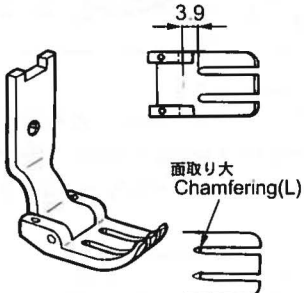
針板 Needle plate	送り歯 Feed dog	押え組 Presser foot assy
		

**T-8422B (糸切り) / T-8422B (With Thread trimmer)**

**厚物用 / For heavy materials**

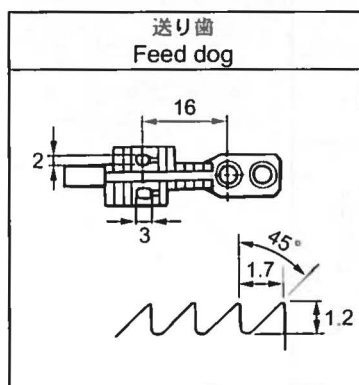

- \* 送り歯が標準品と異なります。
- \* The feed dog is different from normal parts.

針幅 Needle gauge	針抱き組 Needle clamp assy	針板 Needle plate	送り歯 Feed dog	押え組付 Presser foot assy
4.8mm (3/16)	標準品 / Normal	標準品 / Normal	S07905-001	標準品 / Normal
6.4mm (1/4)			158756 -001	

**極薄物用 / For extra light materials**

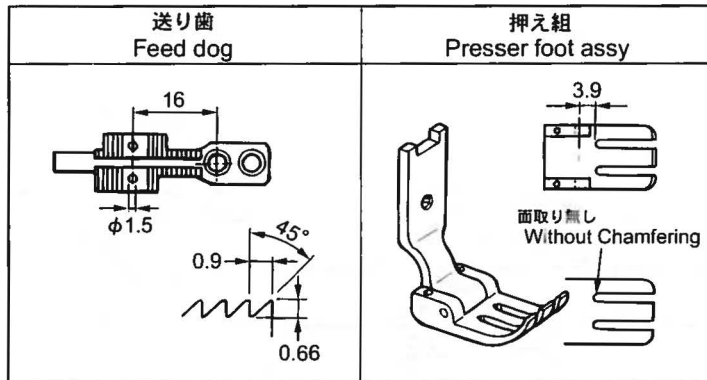

- \* 送り歯と押え組が標準品と異なります。
- \* 押え組の形状は標準品と同じですが、特殊な表面処理が施してあります。
- \* The feed dog and presser foot assembly is different from normal parts.
- \* The shape of the presser foot assembly is the same as for the standard part, but it has a special surface processing.

針幅 Needle gauge	針抱き組 Needle clamp assy	針板 Needle plate	送り歯 Feed dog	押え組 Presser foot assy
4.8mm (3/16)	標準品 / Normal	標準品 / Normal	S36855-001	S36856-001
6.4mm (1/4)			S36858-001	S36859-001

**T-8422B (糸切り) / T-8422B (With Thread trimmer)**

**下送り用 / For Drop Feed**

\* 糸切り用固定刃(S07527-001)と取付ネジ(148539-101)は、針板には付けてありませんので、必要に応じて別途ご注文して下さい。

\* The thread trimming fixed knife (part No. S07527-001) and the installation screw (part No. 148539-101) are not provided with the needle plate, so they must be ordered separately if required.

針幅 Needle gauge	針抱き組 Needle clamp assy	針板 Needle plate		送り歯 Feed dog		押え組 Presser foot assy	
		薄物用 For light materials	極薄物用 For extra light materials	薄物用 For light materials	極薄物用 For extra light materials	薄物用 For light materials	極薄物用 For extra light materials
3.2mm (1/8)	158794-101	S07401-001		S07409-001		S38544-001	
4.8mm (3/16)	158791-101	S07403-001	S36844-001	S07410-001	S36843-001	S38542-001	S36839-001
6.4mm (1/4)	158792-101	S07405-001	S36847-001	S07411-001	S36846-001	S38543-001	S36836-001
7.9mm (5/16)	158793-101	S07676-001		S07680-001		S07682-001	
9.5mm (3/8)	158798-101	S13621-001		S13623-001		S13624-001	
12.7mm (1/2)	158797-101	S07678-001		S07681-001		S07684-101	
19.1mm (3/4)	158806-101	S07886-001		S07888-001		S07889-101	
22.2mm (7/8)	158807-101	S07891-001		S07893-001	S07893-001	S07894-101	
25.4mm (1)	158805-101	S15088-001		S15090-001		S15091-101	
31.8mm (1 1/4)	158799-101	S20914-001		S20916-001		S20917-101	

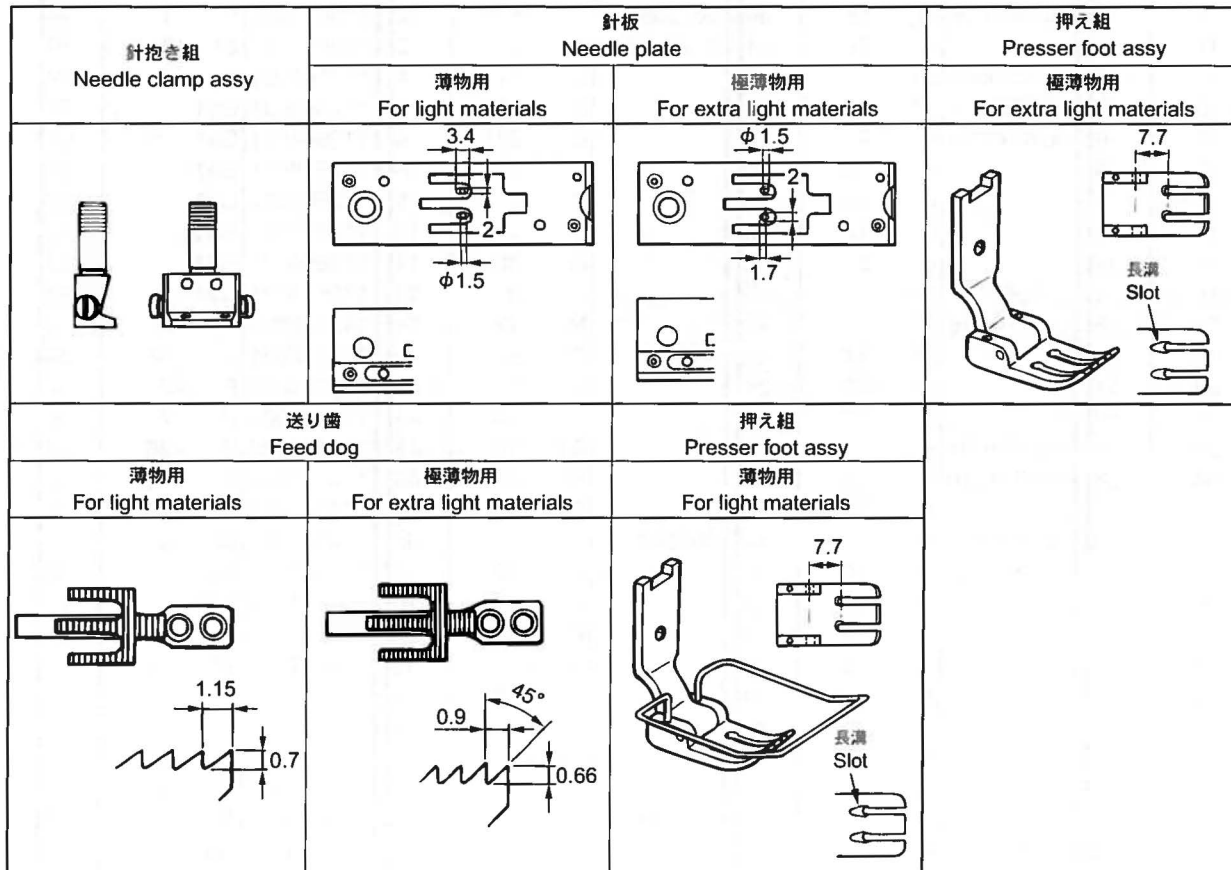

## 索引 / Index

CODE	REF.NO	Page	CODE	REF.NO	Page	CODE	REF.NO	Page	CODE	REF.NO	Page
012060636	C - 39	6	025060136	S1 - 16	46	062400616	J1 - 31	18	081009070	N - 5	36
	E - 33	10	025060236	L - 58	32		J1 - 26	20	081038070	L - 20	30
	F - 15	12	025100132	E - 37	10		J1 - 28	20	0A4261006	S1 - 28	46
	G - 7	14	025710132	J1 - 10	18		J1 - 31	20	0A4300806	S1 - 37	46
	G - 26	14		J2 - 64	22		J2 - 26	22	0A4301006	S1 - 26	46
	M - 44	34		J2 - 64	24		J2 - 28	22	0A4400806	L - 35	30
	P - 31	38	026040236	S1 - 8	46		J2 - 31	22	0A4401005	S1 - 29	46
012061036	B - 32	4	026050136	S1 - 47	46		J2 - 26	24	0A4401006	S1 - 35	46
012061832	D - 18	8	028030246	S1 - 14	46		J2 - 28	24	0A5300606	S1 - 33	46
012500536	B - 17	4	028040242	B - 29	4		J2 - 31	24	0A5501006	L - 23	30
	B - 20	4	028040243	V - 21	54		L - 53	30	100032004	H - 5	16
	D - 26	8	028040245	S2 - 6	48		R - 10	44	100328001	E - 26	10
	M - 31	34	028050244	Z2 - 19	58		S1 - 6	46	100401022	N - 30	36
	N - 8	36	028050246	P - 27	38	062400812	J2 - 69	22	100463001	V - 15	54
	N - 13	36		S1 - 46	46		J2 - 69	24	100463021	Z1 - 49	56
	N - 33	36	028050247	S1 - 21	46	062400863	S2 - 5	48	100477009	Z1 - 13	56
	P - 5	38	031452204	Z2 - 37	58	062401006	V - 19	54	100887001	Z1 - 5	56
	R - 21	44	034422503	V - 30	54	062401216	N - 17	36	104450101	L - 19	30
012501031	J1 - 14	18	048030342	D - 16	8		S1 - 7	46		L - 34	30
	J2 - 14	22		D - 40	8	062401616	L - 43	30		L - 50	30
014060632	Z2 - 33	58	048040342	N - 2	36	062403512	B - 28	4	104821001	E - 45	10
014400632	S1 - 23	46		N - 14	36	062500616	A - 12	2	107415011	Z1 - 11	56
014500632	S1 - 39	46	048060142	F - 9	12		C - 16	6	107415014	Z1 - 11	56
016061031	E - 30	10	048060342	E - 18	10		G - 39	14	107415022	Z1 - 11	56
	F - 13	12	048070342	P - 35	38		L - 46	30	108549001	E - 24	10
017500812	P - 50	38	048080342	E - 36	10		N - 27	36	108801001	L - 48	30
018062032	C - 34	6	048090342	R - 3	44		T - 9	50	108802001	G - 5	14
	C - 44	6	060300606	T - 8	50		T - 11	50	109405001	L - 47	30
	E - 15	10	060400516	R - 13	44		T - 13	50	109714000	Z1 - 34	56
	F - 17	12	061350616	M - 19	34	062500812	F - 6	12	110087001	V - 17	54
018062532	C - 41	6		M - 37	34	062500816	A - 5	2	110087021	Z1 - 54	56
018401036	C - 4	6	062020806	S1 - 4	46		B - 34	4	110161004	Q - 1	42
018501632	S1 - 20	46	062060812	S1 - 15	46		B - 39	4	112603001	Ga1	62
021060306	D - 19	8	062060816	E - 7	10		C - 24	6	112604001	Ga1	62
	D - 36	8		E - 52	10		C - 31	6	112605001	Ga1	62
	P - 45	38		L - 38	30		D - 2	8	112645001	Ga1	62
	Z1 - 24	56		P - 12	38		E - 46	10	112659001	Ga1	62
021300106	M - 11	34		Q - 5	42		G - 38	14	112660001	Ga1	62
021350106	G - 15	14	062061012	P - 10	38		L - 9	30	112661001	Ga1	62
	P - 22	38	062061016	F - 7	12		M - 42	34	112728001	C - 8	6
021400106	S1 - 10	46		J1 - 47	20		P - 59	40	112753001	L - 56	30
021400164	V - 22	54		J2 - 58	24		Q - 3	42	113014000	B - 7	4
021500104	Z2 - 20	58		L - 57	32		R - 23	44	113050001	H - 7	16
	Z2 - 29	58	062061604	Z2 - 30	58		S1 - 18	46	113431002	P - 26	38
	Z2 - 34	58	062061616	C - 32	6		S1 - 43	46	114483002	Z1 - 46	56
	Z2 - 36	58		P - 36	38		S1 - 45	46	114486002	Z1 - 45	56
021500106	D - 29	8	062300416	G - 23	14	062501004	Z2 - 38	58	114941001	M - 41	34
	E - 54	10	062300612	J1 - 18	18	062501016	A - 10	2	114950001	Ga1	62
	P - 28	38		J1 - 18	20		E - 3	10	114951001	Ga1	62
021500316	J1 - 11	18		J2 - 18	22		P - 8	38	114967001	V - 16	54
	J2 - 11	22		J2 - 18	24		P - 18	38	114967021	Z1 - 53	56
025030132	G - 22	14	062300616	M - 39	34		R - 14	44	115947101	J1 - 41	20
025040173	S2 - 7	48		R - 8	44		R - 28	44		J2 - 52	24
025040232	B - 30	4		S1 - 13	46	062501212	J2 - 40	22	116010001	A - 22	2
025040233	V - 20	54	062350512	M - 22	34		J2 - 40	24	116323001	H - 2	16
025050236	E - 49	10	062350816	C - 7	6	062501216	A - 7	2	116498001	Ga1	62
	P - 51	38	062351216	P - 21	38		D - 28	8	116499101	Ga1	62
	R - 24	44	062400416	J1 - 56	20		E - 48	10	116500101	Ga1	62
025060132	G - 13	14		J2 - 68	24		E - 53	10	116501101	Ga1	62
025060136	J1 - 48	20	062400616	G - 18	14	062501404	Z2 - 32	58	116502001	Ga1	62
	J2 - 59	24		G - 33	14	062501416	A - 9	2	116503001	Ga1	62
	N - 6	36		J1 - 26	18	062661212	R - 26	44	116504001	Ga1	62
	N - 15	36		J1 - 28	18	081004070	L - 26	30	116505001	Ga1	62

CODE	REF.NO	Page	CODE	REF.NO	Page	CODE	REF.NO	Page	CODE	REF.NO	Page
116506101	Ga1	62	146194000	V - 28	54	150523001	Ga2	69	158793101	Ga2	69
116507001	Ga1	62	146293001	Z1 - 26	56	150524101	Ga2	69		Ga2	72
116508001	Ga1	62	146367001	V - 10	54	150526001	Ga2	69	158794101	Ga1	62
116509001	Ga1	62	147176001	Ga1	62	150531001	Ga2	69		Ga1	67
116510101	Ga1	62	147177101	Ga1	62	150532101	Ga2	69		Ga2	69
116511001	Ga1	62	147178001	Ga1	62	150534001	Ga2	69		Ga2	72
116512001	Ga1	62	148394000	C - 14	6	150850001	Ga1	62	158795101	Ga1	62
116662003	P - 19	38	148511001	R - 2	44	151027001	J3 - 5	26		Ga2	69
117006001	B - 6	4	148536001	P - 54	38	151029001	Sp	60	158796101	Ga1	62
117133001	Ga1	62	148539101	P - 56	38		Sp	61		Ga2	69
117134001	Ga1	62	148546001	P - 14	38	151030001	J3 - 4	26	158797101	Ga1	62
117158001	Ga1	62		R - 15	44	151076001	Ga1	62		Ga1	67
117160001	H - 5	16	148559100	P - 33	38	151078001	Ga1	62		Ga2	69
117281001	Ga1	65	148602001	J2 - 61	24	151145001	Sp	60		Ga2	72
117365001	Ga1	62	148679001	Ga2	69		Sp	61	158798101	Ga1	62
117367001	Ga1	62	148683001	Ga2	69	151146001	Sp	60		Ga2	69
117368001	Ga1	62	148689001	Ga2	69	151596001	Ga1	62		Ga2	72
117369001	Ga1	62	148697001	Ga2	69	151597101	Ga1	62	158799101	Ga1	62
118735002	C - 35	6	148698001	Ga2	69	151598001	Ga1	62		Ga2	72
118837001	Z1 - 3	56	148699001	Ga2	69	153132000	F - 19	12	158800101	Ga1	62
118945001	Ga1	62	148700001	Ga2	69	153138001	F - 10	12		Ga2	69
118946101	Ga1	62	148701001	Ga2	69	153230101	Z1 - 27	56	158804101	Ga2	69
118947001	Ga1	62	148702001	Ga2	69	153882001	Ga1	64	158805101	Ga1	62
118954000	E - 10	10	148703001	Ga2	69	153887001	Ga1	64		Ga2	69
122991001	Z1 - 1	56	148704001	Ga2	69	153892001	Ga1	64		Ga2	72
129458202	E - 23	10	148705001	Ga2	69	153897001	Ga1	64	158806101	Ga1	67
138843001	Z2 - 28	58	148743001	L - 63	32	154125001	Z1 - 7	56		Ga2	69
140063001	A - 1	2	149095001	F - 18	12	154514001	S1 - 9	46		Ga2	72
140327001	L - 62	32	149311001	Ga1	65	154518001	Sp	60	158807101	Ga1	67
140647101	R - 9	44	149312001	Ga1	65		Sp	61		Ga1	68
	S1 - 5	46	149570001	Z1 - 9	56	154519001	Sp	60		Ga2	69
140890009	L - 55	30	149578000	Z1 - 19	56		Sp	61		Ga2	72
141331002	P - 41	38	149671101	Ga2	69	154560101	M - 28	34	158808001	Ga1	62
	P - 43	38	149673101	Ga2	69	154729001	F - 2	12	158809101	Ga1	62
141544001	J2 - 35	22	149675001	Ga2	69	154730001	F - 3	12		Ga2	69
	J2 - 35	24	149676001	Ga2	69	154731000	F - 4	12	159398001	Ga2	69
142002001	Z1 - 6	56	149677001	Ga2	69	154965001	J1 - 16	18	159400001	Ga2	69
142026003	V - 13	54	149687001	Ga2	69		J1 - 16	20	159402001	Ga2	69
142027001	V - 14	54	149689001	Ga2	69		J2 - 16	22	159404001	Ga2	69
142111001	Ga1	62	149691001	Ga2	69		J2 - 16	24	159577001	Ga1	62
142274101	L - 30	30	149692001	Ga2	69	155510001	M - 29	34	159805001	M - 24	34
142443001	Z1 - 2	56	149799000	V - 29	54	155722001	Ga2	69	228475000	L - 14	30
142721001	Z1 - 8	56	149938001	Ga2	69	155724001	Ga2	69	340400001	P - 60	40
142746122	E - 22	10	149939001	Ga2	69	155851001	Ga2	69	BMP2060-0000000-0G40		
142990001	Z2 - 26	58	149940001	Ga2	69	155853001	Ga2	69		S1 - 48	46
142997001	Z2 - 6	58	149942001	Ga2	69	155855001	Ga2	69	BMP2060-0000000-CG40		
143548000	V - 26	54	149946001	Ga2	69	155857001	Ga2	69		S1 - 48	46
143549000	V - 25	54	149948001	Ga2	69	156112003	Z2 - 15	58	BMP2060-0000000-EG40		
143611201	E - 8	10	149949001	Ga2	69	158115001	K - 13	28		S1 - 48	46
143612100	E - 9	10	149950101	Ga2	69	158430001	Ga1	64	J00494001	S2 - 12	48
143613051	E - 16	10	149952101	Ga2	69	158756001	Ga2	71	J01411001	S2 - 11	48
143616001	E - 17	10	149954001	Ga2	69	158783001	Ga2	69	J03739001	S2 - 13	48
143882001	Z1 - 30	56	149956001	Ga2	69	158784001	Ga2	69	J03955001	S1 - 22	46
143910009	Z1 - 31	56	149960001	Ga2	69	158785001	Ga2	69	J03956001	S1 - 24	46
144226001	Z1 - 15	56	149962101	Ga2	69	158791101	Ga1	62	J03957001	S1 - 25	46
144504001	M - 27	34	149966001	Ga2	69		Ga1	67	J03958001	S1 - 27	46
144881101	Ga1	62	150174000	Z2 - 10	58		Ga2	69	J03964001	S1 - 38	46
144882001	Ga1	62		Z2 - 14	58		Ga2	72	J03975001	S1 - 51	46
145446001	M - 23	34	150179002	Z2 - 18	58	158792101	Ga1	62	J03976001	S1 - 52	46
145446002	N - 29	36	150182000	Z2 - 3	58		Ga1	67	J03983001	S1 - 55	46
145573000	Z1 - 16	56	150183000	Z2 - 25	58		Ga2	69	J03984001	S1 - 56	46
146039121	Z1 - 48	56	150188009	Z2 - 21	58		Ga2	72	J04086001	U - 1	52
146046000	V - 27	54	150206002	Z2 - 8	58	158793101	Ga1	62	J04093001	U - 3	52

## 索引 / Index

CODE	REF.NO	Page	CODE	REF.NO	Page	CODE	REF.NO	Page	CODE	REF.NO	Page
J04096001	U - 5	52	S07388101	Ga2	69	S09260001	J1 - 3	18	S16654101	Ga1	68
J04097001	S2 - 8	48	S07390001	Ga2	69		J2 - 4	22	S16656001	Ga1	68
J04098001	S2 - 8	48	S07391001	Ga2	69	S09261001	J1 - 3	18	S17774001	Z1 - 4	56
J04100001	S2 - 15	48	S07401001	Ga2	72		J2 - 4	22	S19862001	Ga2	69
J04115001	S2 - 25	48	S07403001	Ga2	72	S09365001	Ga1	62	S19864001	Ga2	69
	Wa	59	S07405001	Ga2	72	S10507001	Ga2	69	S19866001	Ga2	69
J04134001	U - 4	52	S07409001	Ga2	72	S10509101	Ga2	69	S19867001	Ga2	69
J04149001	U - 6	52	S07410001	Ga2	72	S10510001	Ga2	69	S19905001	Ga2	69
J04167001	S2 - 10	48	S07411001	Ga2	72	S10550001	V - 9	54	S19907001	Ga2	69
J04168001	S2 - 22	48	S07419001	J1 - 5	18	S10746101	Ga1	62	S19909001	Ga2	69
J04169001	S2 - 21	48		J2 - 6	22	S10751101	Ga1	62	S19910001	Ga2	69
J04195001	S1 - 53	46	S07420000	J1 - 4	18	S10780001	D - 38	8	S20681000	M - 25	34
J04210001	S2 - 23	48		J2 - 5	22	S11244001	H - 4	16	S20682105	M - 26	34
J04230001	S1 - 34	46	S07424001	R - 30	44	S12441001	N - 32	36	S20901001	Ga2	69
J04243001	S2 - 24	48	S07465000	C - 18	6	S13160001	B - 15	4	S20903001	Ga2	69
J04251001	U - 8	52	S07494001	H - 9	16	S13479001	Ga1	67	S20905001	Ga2	69
J04255001	U - 9	52	S07509001	P - 34	38		Ga1	68	S20914001	Ga2	72
J04273001	S1 - 54	46	S07525100	J2 - 34	22	S13480101	Ga1	67	S20916001	Ga2	72
J04296001	S1 - 36	46		J2 - 34	24	S13588001	Ga1	64	S20917101	Ga2	72
J04392001	S1 - 57	46	S07526301	P - 53	38	S13621001	Ga2	72	S21149001	Ga1	64
J04393001	S2 - 1	48	S07527001	P - 55	38	S13623001	Ga2	72	S21150001	Ga1	64
J04436001	S2 - 4	48	S07529001	D - 15	8	S13624001	Ga2	72	S21798001	Z2 - 17	58
J04438001	S2 - 2	48		D - 39	8	S13735001	Ga1	65	S23418002	N - 19	36
J04440001	S2 - 3	48	S07549101	R - 18	44	S14080001	Ga1	65		Z1 - 28	56
J04468001	S2 - 16	48	S07550001	R - 19	44	S14148001	Ga1	62	S23460001	C - 37	6
J04469001	U - 2	52	S07552101	R - 25	44	S14149001	Ga1	62	S23651001	B - 10	4
J04470001	U - 7	52	S07553001	R - 29	44	S14352001	Ga1	68		B - 25	4
J04593001	S2 - 9	48	S07558409	Z2 - 1	58	S14354001	Ga1	68		G - 9	14
J80965001	S2 - 20	48	S07676001	Ga2	72	S14355101	Ga1	68		J2 - 38	22
J80966101	S2 - 20	48	S07678001	Ga2	72	S14357001	Ga1	68		J2 - 38	24
J80967001	S2 - 17	48	S07680001	Ga2	72	S14358101	Ga1	68		K - 11	28
J80968001	S2 - 17	48	S07681001	Ga2	72	S14360001	Ga1	68	S24571001	Ga1	62
J80970001	S2 - 18	48	S07682001	Ga2	72	S14361101	Ga1	68	S24572001	Ga1	62
J80971001	S1 - 30	46	S07684101	Ga1	67	S14363001	Ga1	68	S25234001	B - 3	4
J80973001	S1 - 49	46		Ga2	72	S14364001	Ga1	68	S25235001	B - 11	4
J80974001	S1 - 50	46	S07686001	Ga1	67	S14366001	Ga1	68	S25236001	B - 12	4
J80990001	S1 - 19	46	S07688001	Ga1	67	S14367101	Ga1	68		E - 13	10
J81008001	S2 - 19	48	S07689001	Ga1	67	S14369001	Ga1	68		P - 39	38
S00937001	Ga1	67	S07693001	Ga1	67	S14370001	Ga1	68	S25260001	B - 8	4
	Ga1	68	S07696001	Ga1	67	S14372001	Ga1	68		C - 21	6
S01005000	Z2 - 11	58	S07698001	Ga1	67	S14373101	Ga1	68		C - 28	6
S01641101	Ga2	69	S07699001	Ga1	67	S14375001	Ga1	68	S25289001	D - 9	8
S01644001	Ga2	69	S07703001	Ga1	67	S14376001	Ga1	68	S25344001	Z1 - 22	56
S01646001	Ga2	69	S07729001	V - 11	54	S14378001	Ga1	68	S25475101	Z1 - 23	56
S01928151	J1 - 49	20	S07740001	Sp	60	S14379101	Ga1	68	S25789000	N - 9	36
	J2 - 60	24		Sp	61	S14381001	Ga1	68	S31006001	D - 11	8
	Z1 - 12	56	S07878001	Ga1	64	S14538001	Ga2	69	S31032001	N - 31	36
S02664001	R - 5	44	S07879001	Ga1	64	S14540101	Ga2	69	S31885001	Z1 - 55	56
S02665000	R - 6	44	S07880001	Ga1	64	S14541101	Ga2	69	S31907001	Ga1	62
S02747101	Z2 - 12	58	S07886001	Ga2	72	S14543001	Ga2	69	S31908001	Ga1	62
S04109001	Z2 - 5	58	S07888001	Ga2	72	S14545001	Ga2	69	S32052001	Ga2	69
S07027001	V - 18	54	S07889101	Ga1	67	S14546101	Ga2	69	S32054001	Ga2	69
S07030009	V - 23	54		Ga2	72	S15088001	Ga2	72	S32055101	Ga2	69
S07031009	V - 24	54	S07891001	Ga2	72	S15090001	Ga2	72	S32907050	T - 7	50
S07045009	V - 12	54	S07893001	Ga2	72	S15091101	Ga2	72	S33459001	Ga1	65
S07346101	D - 6	8	S07894101	Ga1	67	S15889001	Z1 - 25	56	S34281000	T - 3	50
S07349001	D - 24	8		Ga2	72	S16102001	Ga2	69	S34438051	A - 21	2
S07350001	D - 37	8	S07905001	Ga2	71	S16104001	Ga2	69	S34756021	Z1 - 52	56
S07351001	D - 14	8	S07996001	Ga1	67	S16106001	Ga2	69	S35820021	Z1 - 50	56
S07353001	D - 13	8	S07997001	Ga1	67	S16107101	Ga2	69	S36010101	Ga1	62
S07355051	D - 27	8		Ga1	68	S16196001	D - 6	8	S36011101	Ga1	62
S07374109	E - 39	10	S07998001	Ga1	67	S16651001	Ga1	68	S36012001	Ga1	62
S07376001	E - 50	10	S07999001	Ga1	67	S16653001	Ga1	68	S36022001	Ga1	62



CODE	REF.NO	Page	CODE	REF.NO	Page	CODE	REF.NO	Page	CODE	REF.NO	Page
S36024001	Ga1	62	S42199051	V - 5	54	SA2442101	A - 8	2	SA2546001	G - 8	14
S36025001	Ga1	62	S42200051	V - 7	54	SA2443101	A - 11	2	SA2550001	G - 24	14
S36544001	Ga1	62	S50098101	E - 25	10	SA2444101	A - 13	2	SA2551001	G - 25	14
S36550001	Ga2	69	S51282101	Z2 - 4	58	SA2445101	A - 15	2	SA2553001	G - 16	14
S36552001	Ga2	69	S51283001	Z2 - 2	58	SA2447001	A - 16	2	SA2554001	G - 17	14
S36554001	Ga2	69	S54024001	V - 3	54	SA2449001	A - 18	2	SA2555001	G - 27	14
S36556001	Ga2	69	S54025001	V - 2	54	SA2452101	B - 1	4	SA2556001	J1 - 40	20
S36663051	A - 20	2	S55663001	Z1 - 14	56	SA2460001	B - 23	4		J1 - 44	20
S36829001	Ga1	64	S58900000	J1 - 55	20	SA2461001	B - 26	4		J2 - 51	24
S36830001	Ga1	64		J2 - 67	24	SA2463001	B - 31	4		J2 - 55	24
S36832001	Ga1	64	SA1120001	B - 9	4	SA2464101	B - 18	4	SA2558001	J1 - 54	20
S36833001	Ga1	64	SA1174001	D - 3	8	SA2469001	B - 33	4		J2 - 66	24
S36835001	Ga1	67	SA1175001	D - 4	8	SA2471001	C - 23	6	SA2560001	J1 - 9	18
S36836001	Ga1	67	SA1179001	D - 23	8	SA2474201	C - 3	6		J2 - 10	22
	Ga2	72		D - 32	8	SA2475101	C - 5	6	SA2562201	J1 - 17	18
S36838001	Ga1	67		D - 34	8	SA2479001	A - 17	2		J2 - 17	22
S36839001	Ga1	67	SA1360101	N - 26	36		A - 19	2	SA2563301	J1 - 33	20
	Ga2	72	SA1385001	S1 - 1	46	SA2481001	C - 26	6		J2 - 43	24
S36841001	Ga1	67	SA1388101	T - 12	50	SA2482001	C - 11	6	SA2565001	J1 - 43	20
S36842001	Ga1	67	SA1390001	T - 6	50	SA2483001	C - 12	6		J2 - 54	24
S36843001	Ga2	72	SA1668111	Sp	60	SA2484001	C - 13	6	SA2566001	G - 14	14
S36844001	Ga2	72	SA1669111	Sp	60	SA2485001	C - 20	6	SA2567001	J1 - 45	20
S36846001	Ga2	72	SA1670111	Sp	60		C - 27	6		J2 - 56	24
S36847001	Ga2	72	SA1671111	Sp	60	SA2486101	C - 30	6	SA2568001	J1 - 46	20
S36855001	Ga2	71	SA1672111	Sp	60	SA2489001	C - 33	6		J2 - 57	24
S36856001	Ga2	71	SA1673011	Sp	60	SA2490101	C - 36	6	SA2571001	K - 5	28
S36858001	Ga2	71	SA1674102	Sp	60	SA2493001	C - 42	6	SA2572001	J1 - 19	18
S36859001	Ga2	71	SA1677111	Sp	61	SA2494001	C - 43	6		J1 - 19	20
S37037001	Z2 - 31	58	SA1678111	Sp	61	SA2495001	D - 1	8		J2 - 19	22
	Z2 - 35	58	SA1679011	Sp	61	SA2496001	D - 7	8		J2 - 19	24
S37060001	A - 25	2	SA1752011	Z1 - 10	56	SA2498001	D - 8	8	SA2574001	J1 - 20	18
	Wa	59	SA1752014	Z1 - 10	56	SA2499001	D - 10	8		J1 - 23	18
S38212001	J1 - 15	18	SA1752022	Z1 - 10	56	SA2500001	D - 20	8		J1 - 20	20
	J2 - 15	22	SA1962001	Z1 - 32	56	SA2501001	D - 21	8		J1 - 23	20
	J2 - 15	24	SA1963001	Z1 - 33	56	SA2502001	D - 22	8		J2 - 20	22
S38266000	L - 11	30	SA1969001	Z1 - 29	56	SA2504001	D - 25	8		J2 - 23	22
S38274001	M - 32	34	SA1971101	N - 1	36		R - 20	44		J2 - 20	24
S38278001	Z1 - 51	56	SA1975001	N - 3	36	SA2506001	D - 30	8		J2 - 23	24
S38300001	Z1 - 47	56	SA1978001	N - 4	36	SA2507001	D - 31	8	SA2575001	J1 - 21	18
S38351001	V - 8	54	SA1980001	N - 7	36	SA2509001	E - 1	10		J1 - 21	20
	Wa	59	SA1981101	N - 10	36	SA2511001	E - 2	10		J2 - 21	22
S38421001	R - 22	44	SA1982101	N - 11	36	SA2512001	E - 4	10		J2 - 21	24
S38422001	E - 19	10	SA1983001	N - 12	36	SA2515001	E - 5	10		K - 7	28
S38426000	R - 4	44	SA1984001	N - 16	36	SA2516001	E - 6	10	SA2578001	D - 42	8
S38427001	E - 20	10	SA1985001	N - 18	36	SA2518001	E - 11	10	SA2579001	J1 - 34	20
S38542001	Ga1	67	SA1988001	N - 20	36	SA2521001	E - 14	10		J2 - 44	24
	Ga2	72	SA1989001	N - 21	36	SA2523001	E - 27	10	SA2580101	K - 6	28
S38543001	Ga1	67	SA1990101	N - 22	36	SA2525001	E - 29	10	SA2582001	Z1 - 20	56
	Ga2	72	SA1991001	N - 23	36	SA2526001	E - 31	10	SA2584001	K - 8	28
S38544001	Ga1	67	SA1992101	N - 25	36	SA2527001	E - 32	10	SA2585001	E - 12	10
	Ga2	72	SA1994101	N - 28	36	SA2528101	E - 34	10		K - 10	28
S38687000	P - 57	40	SA1998001	P - 58	40	SA2529101	E - 35	10		K - 14	28
S38707001	B - 4	4	SA2040001	A - 26	2	SA2530001	E - 38	10	SA2587101	K - 12	28
	K - 9	28		Wa	59	SA2531001	E - 40	10	SA2590001	Z1 - 21	56
S38710001	B - 24	4	SA2041001	A - 26	2	SA2532001	E - 47	10	SA2604001	L - 44	30
S38713100	B - 27	4		Wa	59	SA2533001	E - 51	10	SA2605001	L - 45	30
S38744101	S1 - 2	46	SA2165001	D - 33	8	SA2535101	F - 5	12	SA2606101	L - 49	30
S39048001	R - 7	44	SA2190001	N - 24	36	SA2536001	F - 11	12	SA2607301	M - 1	34
S39051001	D - 12	8	SA2270001	T - 2	50	SA2539001	F - 16	12	SA2613001	M - 4	34
S39830101	E - 28	10	SA2354001	S1 - 40	46	SA2540001	F - 12	12	SA2614201	M - 5	34
S40639001	Z2 - 13	58	SA2378001	P - 38	38	SA2541001	E - 44	10	SA2615001	M - 6	34
S41955051	V - 6	54	SA2440001	A - 3	2	SA2543001	G - 4	14	SA2619001	M - 7	34
S42198051	V - 4	54	SA2441001	A - 6	2	SA2544001	G - 6	14	SA2620001	M - 9	34

## 索引 / Index

CODE	REF.NO	Page	CODE	REF.NO	Page	CODE	REF.NO	Page	CODE	REF.NO	Page
SA2621001	M - 10	34	SA2692101	Z1 - 18	56	SA3175001	S1 - 12	46	SA4098101	T - 4	50
SA2623201	M - 8	34	SA2696001	R - 12	44	SA3414101	M - 2	34	SA4099001	T - 5	50
SA2624001	M - 13	34	SA2707001	V - 1	54	SA3415001	M - 2	34	SA4112101	B - 16	4
SA2625001	M - 14	34	SA2712001	S1 - 17	46	SA3416101	M - 2	34	SA4115101	B - 21	4
SA2626001	M - 12	34	SA2714401	J2 - 1	22	SA3417301	M - 1	34	SA4117001	C - 38	6
	M - 15	34	SA2717001	J2 - 32	22	SA3591001	J1 - 8	18	SA4118001	C - 40	6
SA2627001	M - 16	34		J2 - 32	24	SA3710001	C - 6	6	SA4124301	C - 1	6
SA2628001	M - 17	34	SA2718401	J2 - 42	22	SA3711101	C - 9	6	SA4129101	B - 22	4
SA2629001	M - 18	34	SA2722001	J1 - 42	20	SA3712001	C - 10	6	SA4149101	D - 35	8
SA2630001	M - 21	34		J2 - 53	24	SA3840001	G - 10	14	SA4205101	L - 1	30
SA2632001	M - 30	34	SA2723001	L - 21	30	SA3848001	C - 17	6	SA4212001	M - 3	34
SA2633001	M - 33	34	SA2724001	G - 34	14	SA3852001	C - 19	6	SA4213001	K - 15	28
SA2634001	M - 36	34		L - 22	30	SA3854001	C - 2	6	SA4215101	L - 12	30
SA2635001	M - 38	34	SA2728001	P - 7	38	SA3855001	G - 1	14	SA4444001	J1 - 3	18
SA2636001	M - 43	34	SA2732001	R - 11	44	SA3856001	J1 - 7	18		J2 - 4	22
SA2637001	M - 45	34	SA2755301	J1 - 1	18		J2 - 8	22	SA4458001	J2 - 41	24
SA2638001	M - 46	34	SA2757301	J1 - 32	18	SA3859001	J2 - 9	22	SA4506001	M - 34	34
	M - 49	34	SA2759101	K - 6	28	SA3887001	G - 20	14	SA4507001	M - 35	34
SA2639001	M - 40	34	SA2806001	G - 30	14	SA3888001	G - 21	14	SA4537001	B - 35	4
SA2640001	M - 47	34	SA2818301	M - 1	34	SA3889101	J1 - 12	18	SA4538001	G - 29	14
	M - 48	34	SA2824001	M - 20	34		J2 - 12	22	SA4585001	K - 2	28
	M - 48	34	SA2826001	J2 - 41	24	SA3890001	K - 1	28		K - 4	28
SA2642001	P - 1	38	SA2827001	J1 - 53	20	SA3891001	K - 3	28	SA5026101	L - 3	30
SA2643001	P - 2	38		J2 - 65	24	SA3894001	J1 - 30	18		L - 16	30
SA2644001	P - 3	38	SA2860001	P - 16	38		J1 - 30	20	SA5304001	L - 15	30
SA2645001	P - 4	38	SA2861101	B - 13	4		J2 - 30	22	SA6150101	G - 11	14
	P - 52	38	SA2927001	G - 12	14		J2 - 30	24	SA6151101	G - 37	14
SA2646001	P - 6	38	SA2928001	G - 28	14	SA3912001	J2 - 36	22	SA6152101	G - 11	14
SA2647001	P - 9	38	SA2929001	A - 4	2		J2 - 36	24	SA6153101	G - 37	14
SA2648001	P - 11	38		A - 23	2	SA3922101	Sp	61	SA6166001	B - 5	4
SA2651001	P - 13	38		A - 24	2	SA3923101	L - 42	30	SA6178001	L - 8	30
SA2652101	P - 15	38		L - 10	30	SA3924001	A - 2	2	SA6294101	J1 - 51	18
SA2655001	P - 20	38		L - 18	30	SA3946001	L - 4	30		J1 - 51	20
SA2657001	P - 29	38	SA2935101	B - 14	4	SA3965001	G - 2	14		J2 - 62	22
SA2658001	P - 30	38	SA2936101	B - 14	4	SA3990001	G - 19	14		J2 - 62	24
SA2659001	P - 32	38	SA2950301	J1 - 1	18	SA4007001	C - 15	6	SA6301001	J1 - 22	18
SA2661001	P - 37	38	SA2951301	J1 - 32	18	SA4009001	G - 32	14		J1 - 22	20
SA2663001	P - 40	38	SA2956001	L - 5	30	SA4011001	G - 35	14		J2 - 22	22
SA2665001	P - 42	38	SA2957001	L - 6	30	SA4012001	J1 - 29	18		J2 - 22	24
SA2667001	P - 44	38	SA2958001	B - 19	4		J1 - 29	20	SA6307101	J1 - 52	18
SA2668001	P - 46	38	SA2992001	F - 8	12		J2 - 29	22		J1 - 52	20
SA2669001	P - 47	38		F - 14	12		J2 - 29	24		J2 - 63	22
SA2670101	J2 - 47	24	SA3025001	S1 - 41	46	SA4026001	J1 - 13	18		J2 - 63	24
SA2671001	J2 - 39	22	SA3040001	L - 2	30		J2 - 13	22	SA6308001	G - 31	14
SA2672001	P - 48	38		L - 17	30	SA4028001	G - 3	14	SA6378001	M - 50	34
SA2673001	P - 49	38		L - 32	30	SA4029001	J1 - 2	18	SA6392001	P - 23	38
SA2675001	J2 - 37	22	SA3044001	L - 39	30		J2 - 3	22	SA6393001	P - 24	38
	J2 - 37	24	SA3045201	L - 36	30	SA4033101	L - 13	30	SA6394001	P - 25	38
SA2676001	J2 - 33	22	SA3046001	L - 37	30	SA4038001	J1 - 3	18	SA6395001	P - 17	38
	J2 - 33	24	SA3048101	L - 51	30		J2 - 4	22	SA6414001	L - 61	32
SA2677001	D - 17	8	SA3049001	L - 52	30	SA4040001	S1 - 11	46	SA6415001	L - 29	30
	D - 41	8	SA3054001	J1 - 24	18	SA4044001	J1 - 27	18	SA6416001	L - 60	32
SA2678001	Q - 2	42		J2 - 24	22		J2 - 27	22	SA6417001	J1 - 39	20
SA2679001	Q - 4	42	SA3055101	L - 7	30	SA4045001	J1 - 36	20		J2 - 50	24
SA2680001	R - 1	44		L - 40	30		J2 - 46	24	SA6423001	L - 28	30
SA2682101	R - 16	44		L - 64	30	SA4049101	Ga1	62		L - 59	32
SA2683001	R - 17	44	SA3056001	E - 21	10	SA4050101	Ga2	69	SA6424101	J1 - 25	18
SA2684001	R - 27	44	SA3058101	B - 36	4	SA4051001	Ga2	69		J2 - 25	22
SA2686001	S1 - 3	46	SA3059101	B - 38	4	SA4053101	Ga1	62	SA6425101	J1 - 35	20
SA2687001	S1 - 42	46	SA3060001	L - 33	30	SA4089001	B - 2	4		J2 - 45	24
SA2688201	T - 1	50	SA3062001	E - 1	10	SA4093201	C - 22	6	SA6462001	J1 - 37	20
SA2689101	T - 10	50	SA3065001	B - 37	4	SA4094001	C - 25	6		J2 - 48	24
SA2691101	Z1 - 17	56	SA3072001	F - 1	12	SA4095001	C - 29	6	SA6463001	J1 - 38	20

CODE	REF.NO	Page	CODE	REF.NO	Page	CODE	REF.NO	Page	CODE	REF.NO	Page
SA6463001	J2 - 49	24									
SA6468001	L - 27	30									
SA6472001	L - 41	30									
SA6473001	L - 54	30									
SA6474001	J1 - 6	18									
	J2 - 7	22									
SA6475001	L - 25	30									
SA6592001	E - 43	10									
SA6606001	Z2 - 16	58									
SA6609001	Z2 - 39	58									
SA6610001	Z2 - 22	58									
	Z2 - 24	58									
SA6611001	Z2 - 23	58									
SA6615001	Z2 - 27	58									
SA6627001	Z2 - 7	58									
SA6629001	Z2 - 9	58									
SA7540001	L - 24	30									
SA7548001	L - 31	30									
SA7607001	D - 5	8									
SA7665001	Ga1	62									
SA8364001	P - 61	38									
SA8365001	P - 62	38									
SA8530001	S1 - 44	46									

brother®

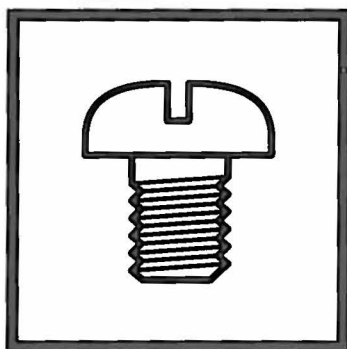

パーツブック  
PARTS BOOK

**ブラザー工業株式会社** <http://www.brother.co.jp/>

〒467-8561 名古屋市瑞穂区苗代町 15 番 1 号 TEL : 0120-33-2392

**BROTHER INDUSTRIES, LTD.** <http://www.brother.com/>

15-1, Naeshiro-cho, Mizuho-ku, Nagoya 467-8561, Japan. Phone : 81-52-824-2177

T-8421B, T8422B  
SA2699-101  
2006.11.B (1)



From the library of: Superior Sewing Machine & Supply LLC